



THE **O** WINE TUMBLER

20 YEARS
ANNIVERSARY

ON PREMISE
PICTURE BOOK 2024

EFFECTIVE: 1ST MAY 2024

IF YOUR WINE COULD CHOOSE A GLASS, IT WOULD BE RIEDEL.

RIEDEL

THE WINE GLASS COMPANY

GRAPE@RIEDEL



TABLE OF CONTENT

NEW ITEMS 2024	
RIEDEL VELOCE RESTAURANT	4
GRAPE@RIEDEL	5
DEGUSTAZIONE	6
RIEDEL RESORT	8
DECANTER MACHINE-MADE	9
ON PREMISE GLASS COLLECTION	
RIEDEL SUPERLEGGERO RESTAURANT	10
RIEDEL VELOCE RESTAURANT	12
RIEDEL WINEWINGS RESTAURANT	16
RIEDEL PERFORMANCE RESTAURANT	18
RIEDEL VERITAS RESTAURANT	20
VINUM RESTAURANT	24
RIEDEL EXTREME RESTAURANT	26
RIEDEL RESTAURANT	28
RIEDEL BAR RESTAURANT	32
RIEDEL WINE FRIENDLY RESTAURANT	34
GRAPE@RIEDEL	35
RIEDEL DRINK SPECIFIC GLASSWARE RESTAURANT	36
OUVERTURE RESTAURANT	39
DEGUSTAZIONE	40
RIEDEL TUMBLER COLLECTION RESTAURANT	42
RIEDEL MANHATTAN	46
SL RIEDEL STEMLESS WINGS RESTAURANT	47
RIEDEL O RESTAURANT	48
SWIRL RESTAURANT	53
RIEDEL RESORT	54
DECANTERS HANDMADE	56
DECANTERS MACHINE-MADE	74
ACCESSORIES	76
LOGO AND POUR AID	78
INSTRUCTIONS	80
TRADEMARK	81
CUSTOM MADE	82
GO GREEN - SUSTAINABILITY	85
GENERAL TERMS AND CONDITIONS	87



Shipments are subject to our General Terms and Conditions and respective Payment and Delivery Terms. We do not accept other delivery Terms and Conditions and respective Payment and Delivery Terms. Our General Terms and Conditions of Contract and respective Payment and Delivery Terms may be viewed by means of display and notice board in our business offices and can be submitted on request. You are accepting these General Terms and Conditions and respective Payment and Delivery Terms when the contract is concluded.

We regret any errors in our specifications for sizes, colours, volumes or prices. However, claims resulting from such errors cannot be accepted. The packaging shown are example packaging.



RIEDEL Veloce Restaurant
Mise en place Tumbler

RIEDEL Veloce Decanter Restaurant

ITEM	Item no.: 0330/20 fine crystal machine-made Height/glass: 118 mm Capacity/glass: 550 ccm Design: 2024	Item no.: 1336/13 fine crystal machine-made Height/glass: 255 mm Capacity/glass: 750 ccm Design: 2024
PACKAGING TYPE AND QUANTITY	Pieces/Bill unit: 1 Bill units/MP: 12	Pieces/Bill unit: 1 Bill units/MP: 6
BILL UNIT DIMENSIONS	Length: 404 mm Width: 303 mm Height: 135 mm Weight: 1150 gr	Length: 384 mm Width: 258 mm Height: 267 mm Weight: 2410 gr
EURO PALLET	Bill units/pallet: 1008 Bill units/layer: 72 Layers/pallet: 14	Bill units/pallet: 378 Bill units/layer: 54 Layers/pallet: 7
CONTAINER PALLET HIGH CUBE	Bill units/pallet: 2040 Bill units/layer: 120 Layers/pallet: 17	Bill units/pallet: 576 Bill units/layer: 72 Layers/pallet: 8
EAN BILL UNIT	 9 006206 327072	 9 006206 326983





GRAPE@RIEDEL
Cabernet/Merlot/Cocktail



GRAPE@RIEDEL
Pinot Noir/Nebbiolo/Aperitivo



GRAPE@RIEDEL
White Wine/Champagne Glass/
Rosé/Spritz Drinks

ITEM	Item no.:	0424/0	Item no.:	0424/07	Item no.:	0424/05
	fine crystal machine-made		fine crystal machine-made		fine crystal machine-made	
	Height/glass:	235 mm	Height/glass:	235 mm	Height/glass:	236 mm
	Capacity/glass:	830 ccm	Capacity/glass:	750 ccm	Capacity/glass:	550 ccm
PACKAGING TYPE AND QUANTITY	Design:	2024	Design:	2024	Design:	2024
	Pieces/Bill unit:	1	Pieces/Bill unit:	1	Pieces/Bill unit:	1
BILL UNIT DIMENSIONS	Bill units/MP:	12	Bill units/MP:	12	Bill units/MP:	12
	Length:	447 mm	Length:	475 mm	Length:	419 mm
	Width:	330 mm	Width:	352 mm	Width:	308 mm
	Height:	253 mm	Height:	252 mm	Height:	252 mm
EURO PALLET	Weight:	2574 gr	Weight:	2618 gr	Weight:	2400 gr
	Bill units/pallet:	420	Bill units/pallet:	336	Bill units/pallet:	504
	Bill units/layer:	60	Bill units/layer:	48	Bill units/layer:	72
	Layers/pallet:	7	Layers/pallet:	7	Layers/pallet:	7
CONTAINER PALLET HIGH CUBE	Bill units/pallet:	756	Bill units/pallet:	756	Bill units/pallet:	972
	Bill units/layer:	84	Bill units/layer:	84	Bill units/layer:	108
	Layers/pallet:	9	Layers/pallet:	9	Layers/pallet:	9
EAN BILL UNIT	 9 006206 327096		 9 006206 327102		 9 006206 327119	

THIS GLASS IS ALSO AVAILABLE
WITH CALIBRATION MARK.

THIS GLASS IS ALSO AVAILABLE
WITH CALIBRATION MARK.

THIS GLASS IS ALSO AVAILABLE
WITH CALIBRATION MARK.



Degustazione
Mise en place

ITEM	Item no.:	0489/05
	fine crystal machine-made	
	Height/glass:	217 mm
	Capacity/glass:	455 ccm
	Design:	2024
PACKAGING	Pieces/Bill unit:	1
TYPE AND QUANTITY	Bill units/MP:	12
BILL UNIT	Length:	359 mm
DIMENSIONS	Width:	264 mm
	Height:	223 mm
	Weight:	2290 gr
EURO PALLET	Bill units/pallet:	864
	Bill units/layer:	108
	Layers/pallet:	8
CONTAINER PALLET	Bill units/pallet:	1440
HIGH CUBE	Bill units/layer:	144
	Layers/pallet:	10
EAN BILL UNIT		

THIS GLASS IS ALSO AVAILABLE
WITH CALIBRATION MARK.

**NO ORDER VOLUME DISCOUNT
EXCLUDED FROM PROMOTIONS**









RIEDEL Resort
Highball



RIEDEL Resort
Double Rocks

ITEM	Item no.: fine crystal Tritan™ from eastman 	0417/94	Item no.: fine crystal Tritan™ from eastman 	0417/97
	Height/glass:	156 mm	Height/glass:	103 mm
	Capacity/glass:	447 ccm	Capacity/glass:	411 ccm
	Design:	2023	Design:	2023
PACKAGING	Pieces/Bill unit:	1	Pieces/Bill unit:	1
TYPE AND QUANTITY	Bill units/MP:	6	Bill units/MP:	6
BILL UNIT	Length:	234 mm	Length:	267 mm
DIMENSIONS	Width:	158 mm	Width:	180 mm
	Height:	166 mm	Height:	114 mm
	Weight:	1361 gr	Weight:	979 gr
EURO PALLET	Bill units/pallet:	1584	Bill units/pallet:	1632
	Bill units/layer:	144	Bill units/layer:	102
	Layers/pallet:	11	Layers/pallet:	16
CONTAINER PALLET	Bill units/pallet:	2496	Bill units/pallet:	2622
HIGH CUBE	Bill units/layer:	192	Bill units/layer:	138
	Layers/pallet:	13	Layers/pallet:	19
EAN				
BILL UNIT	9 006206 326969		9 006206 326952	

tritan™
from eastman



PERFORMANCE

- Durability
- Shatter resistance
- Dishwasher durability



QUALITY

- Clarity
- Style



SAFETY

- BPA free
- Food contact safety
- EA free

**NO ORDER VOLUME DISCOUNT
EXCLUDED FROM PROMOTIONS**



RIEDEL Veloce Decanter Restaurant

ITEM	Item no.: 1336/13 fine crystal machine-made Height/glass: 255 mm Capacity/glass: 750 ccm Design: 2024
PACKAGING	Pieces/Bill unit: 1
TYPE AND QUANTITY	Bill units/MP: 6
BILL UNIT	Length: 384 mm
DIMENSIONS	Width: 258 mm
	Height: 267 mm
	Weight: 2410 gr
EURO PALLET	Bill units/pallet: 378
	Bill units/layer: 54
	Layers/pallet: 7
CONTAINER PALLET	Bill units/pallet: 576
HIGH CUBE	Bill units/layer: 72
	Layers/pallet: 8
EAN	
BILL UNIT	



Bordeaux Grand Cru



Burgundy Grand Cru



Hermitage / Syrah



Riesling

ITEM	Item no.: 0425/00 fine crystal premium machine-made Height/glass: 282 mm Capacity/glass: 953 ccm Design: 2023	Item no.: 0425/16 fine crystal premium machine-made Height/glass: 276 mm Capacity/glass: 1022 ccm Design: 2023	Item no.: 0425/41 fine crystal premium machine-made Height/glass: 267 mm Capacity/glass: 668 ccm Design: 2023	Item no.: 0425/15 fine crystal premium machine-made Height/glass: 252 mm Capacity/glass: 400 ccm Design: 2023
PACKAGING TYPE AND QUANTITY	Pieces/Bill unit: 1 Bill units/MP: 6	Pieces/Bill unit: 1 Bill units/MP: 6	Pieces/Bill unit: 1 Bill units/MP: 6	Pieces/Bill unit: 1 Bill units/MP: 6
BILL UNIT DIMENSIONS	Length: 346 mm Width: 234 mm Height: 305 mm Weight: 1202 gr	Length: 372 mm Width: 249 mm Height: 296 mm Weight: 1237 gr	Length: 329 mm Width: 220 mm Height: 288 mm Weight: 1095 gr	Length: 350 mm Width: 205 mm Height: 275 mm Weight: 996 gr
EURO PALLET	Bill units/pallet: 360 Bill units/layer: 60 Layers/pallet: 6	Bill units/pallet: 324 Bill units/layer: 54 Layers/pallet: 6	Bill units/pallet: 396 Bill units/layer: 66 Layers/pallet: 6	Bill units/pallet: 432 Bill units/layer: 72 Layers/pallet: 6
CONTAINER PALLET HIGH CUBE	Bill units/pallet: 630 Bill units/layer: 90 Layers/pallet: 7	Bill units/pallet: 504 Bill units/layer: 72 Layers/pallet: 7	Bill units/pallet: 630 Bill units/layer: 90 Layers/pallet: 7	Bill units/pallet: 816 Bill units/layer: 102 Layers/pallet: 8
EAN BILL UNIT				





Champagne Wine Glass





Sauvignon Blanc



Chardonnay



Spirits

ITEM	Item no.: 0425/28 fine crystal premium machine-made Height/glass: 260 mm Capacity/glass: 464 ccm Design: 2023	Item no.: 0425/33 fine crystal premium machine-made Height/glass: 261 mm Capacity/glass: 400 ccm Design: 2023	Item no.: 0425/97 fine crystal premium machine-made Height/glass: 234 mm Capacity/glass: 660 ccm Design: 2023	Item no.: 0425/10 fine crystal premium machine-made Height/glass: 244 mm Capacity/glass: 248 ccm Design: 2023
PACKAGING TYPE AND QUANTITY	Pieces/Bill unit: 1 Bill units/MP: 6	Pieces/Bill unit: 1 Bill units/MP: 6	Pieces/Bill unit: 1 Bill units/MP: 6	Pieces/Bill unit: 1 Bill units/MP: 6
BILL UNIT DIMENSIONS	Length: 305 mm Width: 208 mm Height: 280 mm Weight: 898 gr	Length: 305 mm Width: 208 mm Height: 280 mm Weight: 959 gr	Length: 354 mm Width: 236 mm Height: 257 mm Weight: 1150 gr	Length: 305 mm Width: 205 mm Height: 268 mm Weight: 918 gr
EURO PALLET	Bill units/pallet: 432 Bill units/layer: 72 Layers/pallet: 6	Bill units/pallet: 432 Bill units/layer: 72 Layers/pallet: 6	Bill units/pallet: 420 Bill units/layer: 60 Layers/pallet: 7	Bill units/pallet: 504 Bill units/layer: 72 Layers/pallet: 7
CONTAINER PALLET HIGH CUBE	Bill units/pallet: 864 Bill units/layer: 108 Layers/pallet: 8	Bill units/pallet: 864 Bill units/layer: 108 Layers/pallet: 8	Bill units/pallet: 624 Bill units/layer: 78 Layers/pallet: 8	Bill units/pallet: 864 Bill units/layer: 108 Layers/pallet: 8
EAN BILL UNIT	 9 006206 325955	 9 006206 325931	 9 006206 325924	 9 006206 325948



Cabernet/Merlot



Pinot Noir/Nebbiolo



Syrah/Shiraz



Champagne Wine Glass

ITEM	Item no.: 0330/0 fine crystal premium machine-made Height/glass: 247 mm Capacity/glass: 829 ccm Design: 2022	Item no.: 0330/07 fine crystal premium machine-made Height/glass: 247 mm Capacity/glass: 763 ccm Design: 2022	Item no.: 0330/41 fine crystal premium machine-made Height/glass: 247 mm Capacity/glass: 720 ccm Design: 2022	Item no.: 0330/28 fine crystal premium machine-made Height/glass: 247 mm Capacity/glass: 327 ccm Design: 2022
PACKAGING TYPE AND QUANTITY	Pieces/Bill unit: 1 Bill units/MP: 6	Pieces/Bill unit: 1 Bill units/MP: 6	Pieces/Bill unit: 1 Bill units/MP: 6	Pieces/Bill unit: 1 Bill units/MP: 6
BILL UNIT DIMENSIONS	Length: 330 mm Width: 225 mm Height: 270 mm Weight: 1083 gr	Length: 357 mm Width: 240 mm Height: 270 mm Weight: 1211 gr	Length: 320 mm Width: 215 mm Height: 270 mm Weight: 1027 gr	Length: 275 mm Width: 185 mm Height: 270 mm Weight: 849 gr
EURO PALLET	Bill units/pallet: 462 Bill units/layer: 66 Layers/pallet: 7	Bill units/pallet: 378 Bill units/layer: 54 Layers/pallet: 7	Bill units/pallet: 504 Bill units/layer: 72 Layers/pallet: 7	Bill units/pallet: 672 Bill units/layer: 96 Layers/pallet: 7
CONTAINER PALLET HIGH CUBE	Bill units/pallet: 720 Bill units/layer: 90 Layers/pallet: 8	Bill units/pallet: 624 Bill units/layer: 78 Layers/pallet: 8	Bill units/pallet: 768 Bill units/layer: 96 Layers/pallet: 8	Bill units/pallet: 1104 Bill units/layer: 138 Layers/pallet: 8
EAN BILL UNIT				





Sauvignon Blanc





Riesling



Chardonnay



Rosé

ITEM	Item no.: 0330/33 fine crystal premium machine-made Height/glass: 247 mm Capacity/glass: 347 ccm Design: 2022	Item no.: 0330/15 fine crystal premium machine-made Height/glass: 247 mm Capacity/glass: 570 ccm Design: 2022	Item no.: 0330/97 fine crystal premium machine-made Height/glass: 247 mm Capacity/glass: 690 ccm Design: 2022	Item no.: 0330/55 fine crystal premium machine-made Height/glass: 247 mm Capacity/glass: 347 ccm Design: 2022
PACKAGING TYPE AND QUANTITY	Pieces/Bill unit: 1 Bill units/MP: 6	Pieces/Bill unit: 1 Bill units/MP: 6	Pieces/Bill unit: 1 Bill units/MP: 6	Pieces/Bill unit: 1 Bill units/MP: 6
BILL UNIT DIMENSIONS	Length: 275 mm Width: 185 mm Height: 270 mm Weight: 906 gr	Length: 320 mm Width: 220 mm Height: 270 mm Weight: 967 gr	Length: 357 mm Width: 240 mm Height: 270 mm Weight: 1151 gr	Length: 275 mm Width: 185 mm Height: 270 mm Weight: 936 gr
EURO PALLET	Bill units/pallet: 672 Bill units/layer: 96 Layers/pallet: 7	Bill units/pallet: 504 Bill units/layer: 72 Layers/pallet: 7	Bill units/pallet: 378 Bill units/layer: 54 Layers/pallet: 7	Bill units/pallet: 672 Bill units/layer: 96 Layers/pallet: 7
CONTAINER PALLET HIGH CUBE	Bill units/pallet: 1104 Bill units/layer: 138 Layers/pallet: 8	Bill units/pallet: 768 Bill units/layer: 96 Layers/pallet: 8	Bill units/pallet: 624 Bill units/layer: 78 Layers/pallet: 8	Bill units/pallet: 1104 Bill units/layer: 138 Layers/pallet: 8
EAN BILL UNIT	 9 006206 324279	 9 006206 324316	 9 006206 324309	 9 006206 324262







Mis en place Tumbler



RIEDEL Veloce Decanter Restaurant

ITEM	Item no.: 0330/20 fine crystal machine-made Height/glass: 118 mm Capacity/glass: 550 ccm Design: 2024	Item no.: 1336/13 fine crystal machine-made Height/glass: 255 mm Capacity/glass: 750 ccm Design: 2024
PACKAGING TYPE AND QUANTITY	Pieces/Bill unit: 1 Bill units/MP: 12	Pieces/Bill unit: 1 Bill units/MP: 6
BILL UNIT DIMENSIONS	Length: 404 mm Width: 303 mm Height: 135 mm Weight: 1150 gr	Length: 384 mm Width: 258 mm Height: 267 mm Weight: 2410 gr
EURO PALLET	Bill units/pallet: 1008 Bill units/layer: 72 Layers/pallet: 14	Bill units/pallet: 378 Bill units/layer: 54 Layers/pallet: 7
CONTAINER PALLET HIGH CUBE	Bill units/pallet: 2040 Bill units/layer: 120 Layers/pallet: 17	Bill units/pallet: 576 Bill units/layer: 72 Layers/pallet: 8
EAN BILL UNIT	 9 006206 327072	 9 006206 326983





Cabernet/Merlot



Pinot Noir/Nebbiolo



Syrah



Champagne Wine Glass

ITEM	Item no.: 0123/0 fine crystal premium machine-made Height/glass: 250 mm Capacity/glass: 1002 ccm Design: 2020	Item no.: 0123/07 fine crystal premium machine-made Height/glass: 250 mm Capacity/glass: 950 ccm Design: 2020	Item no.: 0123/41 fine crystal premium machine-made Height/glass: 250 mm Capacity/glass: 865 ccm Design: 2020	Item no.: 0123/28 fine crystal premium machine-made Height/glass: 250 mm Capacity/glass: 742 ccm Design: 2020
PACKAGING TYPE AND QUANTITY	Pieces/Bill unit: 1 Bill units/MP: 6	Pieces/Bill unit: 1 Bill units/MP: 6	Pieces/Bill unit: 1 Bill units/MP: 6	Pieces/Bill unit: 1 Bill units/MP: 6
BILL UNIT DIMENSIONS	Length: 374 mm Width: 251 mm Height: 267 mm Weight: 1420 gr	Length: 374 mm Width: 251 mm Height: 267 mm Weight: 1385 gr	Length: 342 mm Width: 230 mm Height: 264 mm Weight: 1388 gr	Length: 342 mm Width: 230 mm Height: 264 mm Weight: 1388 gr
EURO PALLET	Bill units/pallet: 378 Bill units/layer: 54 Layers/pallet: 7	Bill units/pallet: 378 Bill units/layer: 54 Layers/pallet: 7	Bill units/pallet: 420 Bill units/layer: 60 Layers/pallet: 7	Bill units/pallet: 420 Bill units/layer: 60 Layers/pallet: 7
CONTAINER PALLET HIGH CUBE	Bill units/pallet: 576 Bill units/layer: 72 Layers/pallet: 8	Bill units/pallet: 576 Bill units/layer: 72 Layers/pallet: 8	Bill units/pallet: 720 Bill units/layer: 90 Layers/pallet: 8	Bill units/pallet: 720 Bill units/layer: 90 Layers/pallet: 8
EAN BILL UNIT				







Riesling



Sauvignon Blanc



Chardonnay

ITEM	Item no.: 0123/15 fine crystal premium machine-made Height/glass: 250 mm Capacity/glass: 1017 ccm Design: 2020	Item no.: 0123/33 fine crystal premium machine-made Height/glass: 250 mm Capacity/glass: 742 ccm Design: 2020	Item no.: 0123/97 fine crystal premium machine-made Height/glass: 250 mm Capacity/glass: 736 ccm Design: 2020
PACKAGING TYPE AND QUANTITY	Pieces/Bill unit: 1 Bill units/MP: 6	Pieces/Bill unit: 1 Bill units/MP: 6	Pieces/Bill unit: 1 Bill units/MP: 6
BILL UNIT DIMENSIONS	Length: 374 mm Width: 251 mm Height: 267 mm Weight: 1420 gr	Length: 342 mm Width: 230 mm Height: 264 mm Weight: 1388 gr	Length: 342 mm Width: 230 mm Height: 264 mm Weight: 1298 gr
EURO PALLET	Bill units/pallet: 378 Bill units/layer: 54 Layers/pallet: 7	Bill units/pallet: 420 Bill units/layer: 60 Layers/pallet: 7	Bill units/pallet: 420 Bill units/layer: 60 Layers/pallet: 7
CONTAINER PALLET HIGH CUBE	Bill units/pallet: 576 Bill units/layer: 72 Layers/pallet: 8	Bill units/pallet: 720 Bill units/layer: 90 Layers/pallet: 8	Bill units/pallet: 720 Bill units/layer: 90 Layers/pallet: 8
EAN BILL UNIT	 9 006206 531387	 9 006206 531400	 9 006206 531424





Cabernet/Merlot







Pinot Noir



Syrah/Shiraz



Champagne Glass

ITEM	Item no.: 0884/0 fine crystal premium machine-made Height/glass: 245 mm Capacity/glass: 834 ccm Design: 2018	Item no.: 0884/67 fine crystal premium machine-made Height/glass: 245 mm Capacity/glass: 830 ccm Design: 2018	Item no.: 0884/41 fine crystal premium machine-made Height/glass: 245 mm Capacity/glass: 631 ccm Design: 2018	Item no.: 0884/28 fine crystal premium machine-made Height/glass: 245 mm Capacity/glass: 375 ccm Design: 2018
PACKAGING TYPE AND QUANTITY	Pieces/Bill unit: 1 Bill units/MP: 6	Pieces/Bill unit: 1 Bill units/MP: 6	Pieces/Bill unit: 1 Bill units/MP: 6	Pieces/Bill unit: 1 Bill units/MP: 6
BILL UNIT DIMENSIONS	Length: 334 mm Width: 224 mm Height: 268 mm Weight: 1295 gr	Length: 344 mm Width: 231 mm Height: 267 mm Weight: 1303 gr	Length: 319 mm Width: 215 mm Height: 267 mm Weight: 1245 gr	Length: 289 mm Width: 194 mm Height: 267 mm Weight: 1082 gr
EURO PALLET	Bill units/pallet: 462 Bill units/layer: 66 Layers/pallet: 7	Bill units/pallet: 420 Bill units/layer: 60 Layers/pallet: 7	Bill units/pallet: 504 Bill units/layer: 72 Layers/pallet: 7	Bill units/pallet: 672 Bill units/layer: 96 Layers/pallet: 7
CONTAINER PALLET HIGH CUBE	Bill units/pallet: 720 Bill units/layer: 90 Layers/pallet: 8	Bill units/pallet: 720 Bill units/layer: 90 Layers/pallet: 8	Bill units/pallet: 864 Bill units/layer: 108 Layers/pallet: 8	Bill units/pallet: 1056 Bill units/layer: 132 Layers/pallet: 8
EAN BILL UNIT	 9 006206 527564	 9 006206 527540	 9 006206 527595	 9 006206 527557







Sauvignon Blanc



Riesling



Chardonnay

ITEM	Item no.:	0884/33	Item no.:	0884/15	Item no.:	0884/97
	fine crystal premium machine-made		fine crystal premium machine-made		fine crystal premium machine-made	
	Height/glass:	245 mm	Height/glass:	245 mm	Height/glass:	245 mm
	Capacity/glass:	440 ccm	Capacity/glass:	623 ccm	Capacity/glass:	727 ccm
	Design:	2019	Design:	2018	Design:	2018
PACKAGING TYPE AND QUANTITY	Pieces/Bill unit:	1	Pieces/Bill unit:	1	Pieces/Bill unit:	1
	Bill units/MP:	6	Bill units/MP:	6	Bill units/MP:	6
BILL UNIT DIMENSIONS	Length:	289 mm	Length:	319 mm	Length:	344 mm
	Width:	194 mm	Width:	215 mm	Width:	231 mm
	Height:	267 mm	Height:	267 mm	Height:	267 mm
	Weight:	1142 gr	Weight:	1181 gr	Weight:	1303 gr
EURO PALLET	Bill units/pallet:	672	Bill units/pallet:	504	Bill units/pallet:	420
	Bill units/layer:	96	Bill units/layer:	72	Bill units/layer:	60
	Layers/pallet:	7	Layers/pallet:	7	Layers/pallet:	7
CONTAINER PALLET HIGH CUBE	Bill units/pallet:	1056	Bill units/pallet:	864	Bill units/pallet:	720
	Bill units/layer:	132	Bill units/layer:	108	Bill units/layer:	90
	Layers/pallet:	8	Layers/pallet:	8	Layers/pallet:	8
EAN BILL UNIT	 9 006206 529414		 9 006206 527533		 9 006206 527588	





New World Shiraz



Cabernet/Merlot



Old World Pinot Noir



Old World Syrah

ITEM	Item no.: 0449/30 fine crystal premium machine-made Height/glass: 246 mm Capacity/glass: 709 ccm Design: 2014	Item no.: 0449/0 fine crystal premium machine-made Height/glass: 235 mm Capacity/glass: 709 ccm Design: 2014	Item no.: 0449/07 fine crystal premium machine-made Height/glass: 235 mm Capacity/glass: 738 ccm Design: 2014	Item no.: 0449/41 fine crystal premium machine-made Height/glass: 235 mm Capacity/glass: 630 ccm Design: 2014
PACKAGING TYPE AND QUANTITY	Pieces/Bill unit: 1 Bill units/MP: 6	Pieces/Bill unit: 1 Bill units/MP: 6	Pieces/Bill unit: 1 Bill units/MP: 6	Pieces/Bill unit: 1 Bill units/MP: 6
BILL UNIT DIMENSIONS	Length: 305 mm Width: 206 mm Height: 277 mm Weight: 1240 gr	Length: 305 mm Width: 206 mm Height: 264 mm Weight: 1177 gr	Length: 342 mm Width: 230 mm Height: 265 mm Weight: 1222 gr	Length: 305 mm Width: 206 mm Height: 264 mm Weight: 1226 gr
EURO PALLET	Bill units/pallet: 432 Bill units/layer: 72 Layers/pallet: 6	Bill units/pallet: 504 Bill units/layer: 72 Layers/pallet: 7	Bill units/pallet: 420 Bill units/layer: 60 Layers/pallet: 7	Bill units/pallet: 504 Bill units/layer: 72 Layers/pallet: 7
CONTAINER PALLET HIGH CUBE	Bill units/pallet: 960 Bill units/layer: 120 Layers/pallet: 8	Bill units/pallet: 960 Bill units/layer: 120 Layers/pallet: 8	Bill units/pallet: 720 Bill units/layer: 90 Layers/pallet: 8	Bill units/pallet: 960 Bill units/layer: 120 Layers/pallet: 8
EAN BILL UNIT				



RIEDEL VERITAS
 GRAPE  VARIETAL SPECIFIC®
 —RESTAURANT—



New World Pinot Noir/Nebbiolo/Rosé
Champagne Glass







Champagne Wine Glass



Riesling/Zinfandel



Sauvignon Blanc

ITEM	Item no.: 0449/67 fine crystal premium machine-made Height/glass: 235 mm Capacity/glass: 807 ccm Design: 2014	Item no.: 0449/28 fine crystal premium machine-made Height/glass: 235 mm Capacity/glass: 459 ccm Design: 2014	Item no.: 0449/15 fine crystal premium machine-made Height/glass: 235 mm Capacity/glass: 409 ccm Design: 2014	Item no.: 0449/33 fine crystal premium machine-made Height/glass: 235 mm Capacity/glass: 440 ccm Design: 2017
PACKAGING TYPE AND QUANTITY	Pieces/Bill unit: 1 Bill units/MP: 6	Pieces/Bill unit: 1 Bill units/MP: 6	Pieces/Bill unit: 1 Bill units/MP: 6	Pieces/Bill unit: 1 Bill units/MP: 6
BILL UNIT DIMENSIONS	Length: 342 mm Width: 230 mm Height: 265 mm Weight: 1351 gr	Length: 277 mm Width: 186 mm Height: 265 mm Weight: 1032 gr	Length: 263 mm Width: 176 mm Height: 265 mm Weight: 1063 gr	Length: 277 mm Width: 186 mm Height: 265 mm Weight: 1029 gr
EURO PALLET	Bill units/pallet: 420 Bill units/layer: 60 Layers/pallet: 7	Bill units/pallet: 672 Bill units/layer: 96 Layers/pallet: 7	Bill units/pallet: 798 Bill units/layer: 114 Layers/pallet: 7	Bill units/pallet: 672 Bill units/layer: 96 Layers/pallet: 7
CONTAINER PALLET HIGH CUBE	Bill units/pallet: 720 Bill units/layer: 90 Layers/pallet: 8	Bill units/pallet: 1104 Bill units/layer: 138 Layers/pallet: 8	Bill units/pallet: 1248 Bill units/layer: 156 Layers/pallet: 8	Bill units/pallet: 1104 Bill units/layer: 138 Layers/pallet: 8
EAN BILL UNIT	 9 006206 523283	 9 006206 523252	 9 006206 523245	 9 006206 526055

THIS GLASS IS ALSO AVAILABLE
WITH CALIBRATION MARK.



Viognier/Chardonnay







Oaked Chardonnay



Coupe/Cocktail



Spirits

ITEM	Item no.: 0449/05 fine crystal premium machine-made Height/glass: 225 mm Capacity/glass: 381 ccm Design: 2014	Item no.: 0449/97 fine crystal premium machine-made Height/glass: 217 mm Capacity/glass: 655 ccm Design: 2014	Item no.: 0449/09 fine crystal premium machine-made Height/glass: 170 mm Capacity/glass: 310 ccm Design: 2014	Item no.: 0449/71 fine crystal premium machine-made Height/glass: 235 mm Capacity/glass: 170 ccm Design: 2016
PACKAGING TYPE AND QUANTITY	Pieces/Bill unit: 1 Bill units/MP: 6	Pieces/Bill unit: 1 Bill units/MP: 6	Pieces/Bill unit: 1 Bill units/MP: 6	Pieces/Bill unit: 1 Bill units/MP: 6
BILL UNIT DIMENSIONS	Length: 264 mm Width: 183 mm Height: 255 mm Weight: 1042 gr	Length: 338 mm Width: 229 mm Height: 245 mm Weight: 1224 gr	Length: 336 mm Width: 225 mm Height: 199 mm Weight: 1020 gr	Length: 265 mm Width: 179 mm Height: 263 mm Weight: 957 gr
EURO PALLET	Bill units/pallet: 798 Bill units/layer: 114 Layers/pallet: 7	Bill units/pallet: 462 Bill units/layer: 66 Layers/pallet: 7	Bill units/pallet: 594 Bill units/layer: 66 Layers/pallet: 9	Bill units/pallet: 798 Bill units/layer: 114 Layers/pallet: 7
CONTAINER PALLET HIGH CUBE	Bill units/pallet: 1350 Bill units/layer: 150 Layers/pallet: 9	Bill units/pallet: 810 Bill units/layer: 90 Layers/pallet: 9	Bill units/pallet: 990 Bill units/layer: 90 Layers/pallet: 11	Bill units/pallet: 1248 Bill units/layer: 156 Layers/pallet: 8
EAN BILL UNIT	 9 006206 523214	 9 006206 523290	 9 006206 523238	 9 006206 525355



Beer

ITEM	Item no.: 0449/11 fine crystal premium machine-made Height/glass: 160 mm Capacity/glass: 459 ccm Design: 2016
PACKAGING	Pieces/Bill unit: 1
TYPE AND QUANTITY	Bill units/MP: 6
BILL UNIT	Length: 274 mm
DIMENSIONS	Width: 184 mm
	Height: 186 mm
	Weight: 954 gr
EURO PALLET	Bill units/pallet: 1020
	Bill units/layer: 102
	Layers/pallet: 10
CONTAINER PALLET	Bill units/pallet: 1656
HIGH CUBE	Bill units/layer: 138
	Layers/pallet: 12
EAN	
BILL UNIT	



Syrah/Shiraz/Tempranillo





Cabernet Sauvignon/Merlot



Pinot Noir (Burgundy Red)



Zinfandel

ITEM	Item no.: 0416/306 fine crystal premium machine-made Height/glass: 236 mm Capacity/glass: 692 ccm Design: 1995	Item no.: 0416/06 fine crystal premium machine-made Height/glass: 225 mm Capacity/glass: 650 ccm Design: 1986	Item no.: 0416/076 fine crystal premium machine-made Height/glass: 210 mm Capacity/glass: 725 ccm Design: 1986	Item no.: 0416/156 fine crystal premium machine-made Height/glass: 210 mm Capacity/glass: 404 ccm Design: 1992
PACKAGING TYPE AND QUANTITY	Pieces/Bill unit: 1 Bill units/MP: 6	Pieces/Bill unit: 1 Bill units/MP: 6	Pieces/Bill unit: 1 Bill units/MP: 6	Pieces/Bill unit: 1 Bill units/MP: 6
BILL UNIT DIMENSIONS	Length: 305 mm Width: 205 mm Height: 261 mm Weight: 1328 gr	Length: 305 mm Width: 205 mm Height: 255 mm Weight: 1271 gr	Length: 342 mm Width: 231 mm Height: 241 mm Weight: 1347 gr	Length: 256 mm Width: 174 mm Height: 242 mm Weight: 1089 gr
EURO PALLET	Bill units/pallet: 504 Bill units/layer: 72 Layers/pallet: 7	Bill units/pallet: 504 Bill units/layer: 72 Layers/pallet: 7	Bill units/pallet: 420 Bill units/layer: 60 Layers/pallet: 7	Bill units/pallet: 840 Bill units/layer: 120 Layers/pallet: 7
CONTAINER PALLET HIGH CUBE	Bill units/pallet: 960 Bill units/layer: 120 Layers/pallet: 8	Bill units/pallet: 1080 Bill units/layer: 120 Layers/pallet: 9	Bill units/pallet: 810 Bill units/layer: 90 Layers/pallet: 9	Bill units/pallet: 1512 Bill units/layer: 168 Layers/pallet: 9
EAN BILL UNIT	 9 006206 510030	 9 006206 510016	 9 006206 510023	 9 006206 510047



Riesling Grand Cru







Viognier/Chardonnay



Champagne Wine Glass



Cuvée Prestige

ITEM	Item no.: 0416/156 fine crystal premium machine-made Height/glass: 210 mm Capacity/glass: 404 ccm Design: 1992	Item no.: 0416/056 fine crystal premium machine-made Height/glass: 198 mm Capacity/glass: 370 ccm Design: 1986	Item no.: 0416/586 fine crystal premium machine-made Height/glass: 225 mm Capacity/glass: 445 ccm Design: 2018	Item no.: 0416/486 fine crystal premium machine-made Height/glass: 218 mm Capacity/glass: 230 ccm Design: 1999
PACKAGING TYPE AND QUANTITY	Pieces/Bill unit: 1 Bill units/MP: 6	Pieces/Bill unit: 1 Bill units/MP: 6	Pieces/Bill unit: 1 Bill units/MP: 6	Pieces/Bill unit: 1 Bill units/MP: 6
BILL UNIT DIMENSIONS	Length: 256 mm Width: 174 mm Height: 242 mm Weight: 1089 gr	Length: 260 mm Width: 175 mm Height: 228 mm Weight: 1040 gr	Length: 277 mm Width: 185 mm Height: 241 mm Weight: 1275 gr	Length: 227 mm Width: 154 mm Height: 248 mm Weight: 1043 gr
EURO PALLET	Bill units/pallet: 840 Bill units/layer: 120 Layers/pallet: 7	Bill units/pallet: 912 Bill units/layer: 114 Layers/pallet: 8	Bill units/pallet: 672 Bill units/layer: 96 Layers/pallet: 7	Bill units/pallet: 1050 Bill units/layer: 150 Layers/pallet: 7
CONTAINER PALLET HIGH CUBE	Bill units/pallet: 1512 Bill units/layer: 168 Layers/pallet: 9	Bill units/pallet: 1680 Bill units/layer: 168 Layers/pallet: 10	Bill units/pallet: 1242 Bill units/layer: 138 Layers/pallet: 9	Bill units/pallet: 1944 Bill units/layer: 216 Layers/pallet: 9
EAN BILL UNIT	 9 006206 510047	 9 006206 510054	 9 006206 527526	 9 006206 510122



Cabernet



Pinot Noir



Shiraz



Riesling/Sauvignon Blanc

ITEM	Item no.: 0454/0 fine crystal machine-made Height/glass: 247 mm Capacity/glass: 800 ccm Design: 2017	Item no.: 0454/07 fine crystal machine-made Height/glass: 243 mm Capacity/glass: 770 ccm Design: 2017	Item no.: 0454/32 fine crystal machine-made Height/glass: 244 mm Capacity/glass: 709 ccm Design: 2017	Item no.: 0454/05 fine crystal machine-made Height/glass: 240 mm Capacity/glass: 490 ccm Design: 2017
PACKAGING TYPE AND QUANTITY	Pieces/Bill unit: 1 Bill units/MP: 12	Pieces/Bill unit: 1 Bill units/MP: 12	Pieces/Bill unit: 1 Bill units/MP: 12	Pieces/Bill unit: 1 Bill units/MP: 12
BILL UNIT DIMENSIONS	Length: 446 mm Width: 326 mm Height: 252 mm Weight: 2806 gr	Length: 479 mm Width: 357 mm Height: 257 mm Weight: 3011 gr	Length: 446 mm Width: 326 mm Height: 252 mm Weight: 2822 gr	Length: 374 mm Width: 276 mm Height: 250 mm Weight: 2458 gr
EURO PALLET	Bill units/pallet: 420 Bill units/layer: 60 Layers/pallet: 7	Bill units/pallet: 336 Bill units/layer: 48 Layers/pallet: 7	Bill units/pallet: 420 Bill units/layer: 60 Layers/pallet: 7	Bill units/pallet: 672 Bill units/layer: 96 Layers/pallet: 7
CONTAINER PALLET HIGH CUBE	Bill units/pallet: 768 Bill units/layer: 96 Layers/pallet: 8	Bill units/pallet: 648 Bill units/layer: 72 Layers/pallet: 9	Bill units/pallet: 768 Bill units/layer: 96 Layers/pallet: 8	Bill units/pallet: 1188 Bill units/layer: 132 Layers/pallet: 9
EAN BILL UNIT	 9 006206 513000	 9 006206 513024	 9 006206 312689	 9 006206 513017





Rosé Wine







Oaked Chardonnay



Prosecco Superiore



Martini

ITEM	Item no.: 0454/55 fine crystal machine-made Height/glass: 230 mm Capacity/glass: 322 ccm Design: 2017	Item no.: 0454/97 fine crystal machine-made Height/glass: 227 mm Capacity/glass: 670 ccm Design: 2017	Item no.: 0454/85 fine crystal machine-made Height/glass: 222 mm Capacity/glass: 305 ccm Design: 2017	Item no.: 0454/17 fine crystal machine-made Height/glass: 175 mm Capacity/glass: 250 ccm Design: 2017
PACKAGING TYPE AND QUANTITY	Pieces/Bill unit: 1 Bill units/MP: 12	Pieces/Bill unit: 1 Bill units/MP: 12	Pieces/Bill unit: 1 Bill units/MP: 12	Pieces/Bill unit: 1 Bill units/MP: 12
BILL UNIT DIMENSIONS	Length: 366 mm Width: 269 mm Height: 242 mm Weight: 2365 gr	Length: 479 mm Width: 357 mm Height: 251 mm Weight: 2770 gr	Length: 366 mm Width: 269 mm Height: 242 mm Weight: 2445 gr	Length: 479 mm Width: 357 mm Height: 257 mm Weight: 2376 gr
EURO PALLET	Bill units/pallet: 672 Bill units/layer: 96 Layers/pallet: 7	Bill units/pallet: 336 Bill units/layer: 48 Layers/pallet: 7	Bill units/pallet: 672 Bill units/layer: 96 Layers/pallet: 7	Bill units/pallet: 336 Bill units/layer: 48 Layers/pallet: 7
CONTAINER PALLET HIGH CUBE	Bill units/pallet: 1188 Bill units/layer: 132 Layers/pallet: 9	Bill units/pallet: 648 Bill units/layer: 72 Layers/pallet: 9	Bill units/pallet: 1188 Bill units/layer: 132 Layers/pallet: 9	Bill units/pallet: 648 Bill units/layer: 72 Layers/pallet: 9
EAN BILL UNIT	 9 006206 524105	 9 006206 513031	 9 006206 524112	 9 006206 513048



Bordeaux Grand Cru



Old World Syrah



New World Pinot Noir



New World Shiraz

ITEM	Item no.: 0447/00 fine crystal machine-made Height/glass: 255 mm Capacity/glass: 960 ccm Design: 2010	Item no.: 0447/30 fine crystal machine-made Height/glass: 238 mm Capacity/glass: 640 ccm Design: 2010	Item no.: 0447/07 fine crystal machine-made Height/glass: 229 mm Capacity/glass: 850 ccm Design: 2010	Item no.: 0446/30 fine crystal machine-made Height/glass: 226 mm Capacity/glass: 650 ccm Design: 2002
PACKAGING TYPE AND QUANTITY	Pieces/Bill unit: 1 Bill units/MP: 12	Pieces/Bill unit: 1 Bill units/MP: 12	Pieces/Bill unit: 1 Bill units/MP: 12	Pieces/Bill unit: 1 Bill units/MP: 12
BILL UNIT DIMENSIONS	Length: 463 mm Width: 344 mm Height: 267 mm Weight: 3117 gr	Length: 410 mm Width: 306 mm Height: 252 mm Weight: 3005 gr	Length: 444 mm Width: 332 mm Height: 243 mm Weight: 2600 gr	Length: 444 mm Width: 332 mm Height: 243 mm Weight: 2552 gr
EURO PALLET	Bill units/pallet: 336 Bill units/layer: 48 Layers/pallet: 7	Bill units/pallet: 504 Bill units/layer: 72 Layers/pallet: 7	Bill units/pallet: 420 Bill units/layer: 60 Layers/pallet: 7	Bill units/pallet: 504 Bill units/layer: 72 Layers/pallet: 7
CONTAINER PALLET HIGH CUBE	Bill units/pallet: 672 Bill units/layer: 84 Layers/pallet: 8	Bill units/pallet: 972 Bill units/layer: 108 Layers/pallet: 9	Bill units/pallet: 864 Bill units/layer: 96 Layers/pallet: 9	Bill units/pallet: 972 Bill units/layer: 108 Layers/pallet: 9
EAN BILL UNIT				

REBSORTEN SPEZIFISCH®

RIEDEL

—RESTAURANT—



Cabernet/Merlot







Old World Pinot Noir



Zinfandel



Champagne Glass

ITEM	Item no.: 0446/0 fine crystal machine-made Height/glass: 217 mm Capacity/glass: 610 ccm Design: 2001	Item no.: 0446/07 fine crystal machine-made Height/glass: 215 mm Capacity/glass: 700 ccm Design: 2001	Item no.: 0446/15 fine crystal machine-made Height/glass: 214 mm Capacity/glass: 370 ccm Design: 2002	Item no.: 0446/48 fine crystal machine-made Height/glass: 217 mm Capacity/glass: 260 ccm Design: 2001
PACKAGING TYPE AND QUANTITY	Pieces/Bill unit: 1 Bill units/MP: 12	Pieces/Bill unit: 1 Bill units/MP: 12	Pieces/Bill unit: 1 Bill units/MP: 12	Pieces/Bill unit: 1 Bill units/MP: 12
BILL UNIT DIMENSIONS	Length: 444 mm Width: 332 mm Height: 243 mm Weight: 2496 gr	Length: 455 mm Width: 338 mm Height: 234 mm Weight: 2614 gr	Length: 339 mm Width: 246 mm Height: 218 mm Weight: 2188 gr	Length: 299 mm Width: 221 mm Height: 229 mm Weight: 1803 gr
EURO PALLET	Bill units/pallet: 504 Bill units/layer: 72 Layers/pallet: 7	Bill units/pallet: 480 Bill units/layer: 60 Layers/pallet: 8	Bill units/pallet: 960 Bill units/layer: 120 Layers/pallet: 8	Bill units/pallet: 1248 Bill units/layer: 156 Layers/pallet: 8
CONTAINER PALLET HIGH CUBE	Bill units/pallet: 972 Bill units/layer: 108 Layers/pallet: 9	Bill units/pallet: 756 Bill units/layer: 84 Layers/pallet: 9	Bill units/pallet: 1680 Bill units/layer: 168 Layers/pallet: 10	Bill units/pallet: 2160 Bill units/layer: 216 Layers/pallet: 10
EAN BILL UNIT	 9 006206 511761	 9 006206 511747	 9 006206 511730	 9 006206 511945

THIS GLASS IS ALSO AVAILABLE
WITH CALIBRATION MARK.

THIS GLASS IS ALSO AVAILABLE
WITH CALIBRATION MARK.

THIS GLASS IS ALSO AVAILABLE
WITH CALIBRATION MARK.



Champagne Wine Glass



Riesling



Viognier/Chardonnay



Oaked Chardonnay

ITEM	Item no.: 0446/58 fine crystal machine-made Height/glass: 221 mm Capacity/glass: 440 ccm Design: 2018	Item no.: 0446/15 fine crystal machine-made Height/glass: 214 mm Capacity/glass: 370 ccm Design: 2002	Item no.: 0446/05 fine crystal machine-made Height/glass: 203 mm Capacity/glass: 350 ccm Design: 2001	Item no.: 0446/97 fine crystal machine-made Height/glass: 197 mm Capacity/glass: 700 ccm Design: 2001
PACKAGING TYPE AND QUANTITY	Pieces/Bill unit: 1 Bill units/MP: 12	Pieces/Bill unit: 1 Bill units/MP: 12	Pieces/Bill unit: 1 Bill units/MP: 12	Pieces/Bill unit: 1 Bill units/MP: 12
BILL UNIT DIMENSIONS	Length: 367 mm Width: 271 mm Height: 230 mm Weight: 2304 gr	Length: 339 mm Width: 246 mm Height: 218 mm Weight: 2188 gr	Length: 339 mm Width: 246 mm Height: 218 mm Weight: 2140 gr	Length: 455 mm Width: 338 mm Height: 234 mm Weight: 2695 gr
EURO PALLET	Bill units/pallet: 768 Bill units/layer: 96 Layers/pallet: 8	Bill units/pallet: 960 Bill units/layer: 120 Layers/pallet: 8	Bill units/pallet: 960 Bill units/layer: 120 Layers/pallet: 8	Bill units/pallet: 480 Bill units/layer: 60 Layers/pallet: 8
CONTAINER PALLET HIGH CUBE	Bill units/pallet: 1320 Bill units/layer: 132 Layers/pallet: 10	Bill units/pallet: 1680 Bill units/layer: 168 Layers/pallet: 10	Bill units/pallet: 1680 Bill units/layer: 168 Layers/pallet: 10	Bill units/pallet: 756 Bill units/layer: 84 Layers/pallet: 9
EAN BILL UNIT				

THIS GLASS IS ALSO AVAILABLE WITH CALIBRATION MARK.

THIS GLASS IS ALSO AVAILABLE WITH CALIBRATION MARK.



Water

ITEM	Item no.:	0446/02
	fine crystal machine-made	
	Height/glass:	145 mm
	Capacity/glass:	350 ccm
	Design:	2001
PACKAGING	Pieces/Bill unit:	1
TYPE AND QUANTITY	Bill units/MP:	12
BILL UNIT	Length:	341 mm
DIMENSIONS	Width:	257 mm
	Height:	174 mm
	Weight:	1717 gr
	EURO PALLET	Bill units/pallet:
	Bill units/layer:	120
	Layers/pallet:	11
CONTAINER PALLET	Bill units/pallet:	2184
HIGH CUBE	Bill units/layer:	168
	Layers/pallet:	13
	EAN	
BILL UNIT		





Tequila







Rum/Aquavit



Cognac



Port

ITEM	Item no.: 0446/18 fine crystal machine-made Height/glass: 210 mm Capacity/glass: 190 ccm Design: 2006	Item no.: 0512/10 fine crystal machine-made Height/glass: 205 mm Capacity/glass: 200 ccm Design: 2022	Item no.: 0446/71 fine crystal machine-made Height/glass: 190 mm Capacity/glass: 175 ccm Design: 2006	Item no.: 0446/60 fine crystal machine-made Height/glass: 176 mm Capacity/glass: 265 ccm Design: 2011
PACKAGING TYPE AND QUANTITY	Pieces/Bill unit: 1 Bill units/MP: 12	Pieces/Bill unit: 1 Bill units/MP: 12	Pieces/Bill unit: 1 Bill units/MP: 12	Pieces/Bill unit: 1 Bill units/MP: 12
BILL UNIT DIMENSIONS	Length: 295 mm Width: 219 mm Height: 232 mm Weight: 1745 gr	Length: 340 mm Width: 245 mm Height: 220 mm Weight: 1828 gr	Length: 311 mm Width: 230 mm Height: 199 mm Weight: 1701 gr	Length: 311 mm Width: 230 mm Height: 186 mm Weight: 1667 gr
EURO PALLET	Bill units/pallet: 1248 Bill units/layer: 156 Layers/pallet: 8	Bill units/pallet: 960 Bill units/layer: 120 Layers/pallet: 8	Bill units/pallet: 1296 Bill units/layer: 144 Layers/pallet: 9	Bill units/pallet: 1440 Bill units/layer: 144 Layers/pallet: 10
CONTAINER PALLET HIGH CUBE	Bill units/pallet: 2160 Bill units/layer: 216 Layers/pallet: 10	Bill units/pallet: 1680 Bill units/layer: 168 Layers/pallet: 10	Bill units/pallet: 2112 Bill units/layer: 192 Layers/pallet: 11	Bill units/pallet: 2304 Bill units/layer: 192 Layers/pallet: 12
EAN BILL UNIT	 9 006206 514861	 9 006206 323340	 9 006206 513963	 9 006206 516193



Beer



Single Malt Whisky



Whisky



Water

ITEM	Item no.: fine crystal machine-made	0446/11	Item no.: fine crystal machine-made	0446/80	Item no.: fine crystal machine-made	0480/02	Item no.: fine crystal machine-made	0480/01
	Height/glass:	170 mm	Height/glass:	113 mm	Height/glass:	100 mm	Height/glass:	80 mm
	Capacity/glass:	500 ccm	Capacity/glass:	189 ccm	Capacity/glass:	430 ccm	Capacity/glass:	330 ccm
	Design:	2002	Design:	2008	Design:	2009	Design:	2007
PACKAGING	Pieces/Bill unit:	1	Pieces/Bill unit:	1	Pieces/Bill unit:	1	Pieces/Bill unit:	1
TYPE AND QUANTITY	Bill units/MP:	12	Bill units/MP:	12	Bill units/MP:	12	Bill units/MP:	12
BILL UNIT	Length:	368 mm	Length:	295 mm	Length:	343 mm	Length:	343 mm
DIMENSIONS	Width:	275 mm	Width:	220 mm	Width:	254 mm	Width:	254 mm
	Height:	186 mm	Height:	128 mm	Height:	111 mm	Height:	111 mm
	Weight:	2276 gr	Weight:	1623 gr	Weight:	1828 gr	Weight:	1579 gr
EURO PALLET	Bill units/pallet:	960	Bill units/pallet:	2340	Bill units/pallet:	1920	Bill units/pallet:	1920
	Bill units/layer:	96	Bill units/layer:	156	Bill units/layer:	120	Bill units/layer:	120
	Layers/pallet:	10	Layers/pallet:	15	Layers/pallet:	16	Layers/pallet:	16
CONTAINER PALLET	Bill units/pallet:	1584	Bill units/pallet:	3888	Bill units/pallet:	3360	Bill units/pallet:	3360
HIGH CUBE	Bill units/layer:	132	Bill units/layer:	216	Bill units/layer:	168	Bill units/layer:	168
	Layers/pallet:	12	Layers/pallet:	18	Layers/pallet:	20	Layers/pallet:	20
EAN	 9 006206 511990		 9 006206 515455		 9 006206 515448		 9 006206 513208	
BILL UNIT								





Magnum
RIEDEL 001



Red Wine
RIEDEL 002



White Wine/Champagne Wine Glass
RIEDEL 003

ITEM	Item no.:	0260/0	Item no.:	0260/02	Item no.:	0260/03
	fine crystal machine-made		fine crystal machine-made		fine crystal machine-made	
	Height/glass:	261 mm	Height/glass:	247 mm	Height/glass:	221 mm
	Capacity/glass:	995 ccm	Capacity/glass:	667 ccm	Capacity/glass:	440 ccm
	Design:	2016	Design:	2020	Design:	2022
PACKAGING TYPE AND QUANTITY	Pieces/Bill unit:	1	Pieces/Bill unit:	1	Pieces/Bill unit:	1
	Bill units/MP:	12	Bill units/MP:	12	Bill units/MP:	12
BILL UNIT DIMENSIONS	Length:	463 mm	Length:	419 mm	Length:	367 mm
	Width:	344 mm	Width:	308 mm	Width:	271 mm
	Height:	267 mm	Height:	252 mm	Height:	230 mm
	Weight:	3164 gr	Weight:	2486 gr	Weight:	2356 gr
EURO PALLET	Bill units/pallet:	336	Bill units/pallet:	504	Bill units/pallet:	768
	Bill units/layer:	48	Bill units/layer:	72	Bill units/layer:	96
	Layers/pallet:	7	Layers/pallet:	7	Layers/pallet:	8
CONTAINER PALLET HIGH CUBE	Bill units/pallet:	672	Bill units/pallet:	972	Bill units/pallet:	1320
	Bill units/layer:	84	Bill units/layer:	108	Bill units/layer:	132
	Layers/pallet:	8	Layers/pallet:	9	Layers/pallet:	10
EAN BILL UNIT	 9 006206 525270		 9 006206 320639		 9 006206 320981	



Cabernet/Merlot/Cocktail



Pinot Noir/Nebbiolo/Aperitivo



White Wine/Champagne Glass/
Rosé/Spritz Drinks

ITEM	Item no.:	0424/0	Item no.:	0424/07	Item no.:	0424/05
	fine crystal machine-made		fine crystal machine-made		fine crystal machine-made	
	Height/glass:	235 mm	Height/glass:	235 mm	Height/glass:	236 mm
	Capacity/glass:	830 ccm	Capacity/glass:	750 ccm	Capacity/glass:	550 ccm
	Design:	2024	Design:	2024	Design:	2024
PACKAGING TYPE AND QUANTITY	Pieces/Bill unit:	1	Pieces/Bill unit:	1	Pieces/Bill unit:	1
	Bill units/MP:	12	Bill units/MP:	12	Bill units/MP:	12
BILL UNIT DIMENSIONS	Length:	447 mm	Length:	475 mm	Length:	419 mm
	Width:	330 mm	Width:	352 mm	Width:	308 mm
	Height:	253 mm	Height:	252 mm	Height:	252 mm
	Weight:	2574 gr	Weight:	2618 gr	Weight:	2400 gr
EURO PALLET	Bill units/pallet:	420	Bill units/pallet:	336	Bill units/pallet:	504
	Bill units/layer:	60	Bill units/layer:	48	Bill units/layer:	72
	Layers/pallet:	7	Layers/pallet:	7	Layers/pallet:	7
CONTAINER PALLET HIGH CUBE	Bill units/pallet:	756	Bill units/pallet:	756	Bill units/pallet:	972
	Bill units/layer:	84	Bill units/layer:	84	Bill units/layer:	108
	Layers/pallet:	9	Layers/pallet:	9	Layers/pallet:	9
EAN BILL UNIT	 9 006206 327096		 9 006206 327102		 9 006206 327119	

THIS GLASS IS ALSO AVAILABLE
WITH CALIBRATION MARK.

THIS GLASS IS ALSO AVAILABLE
WITH CALIBRATION MARK.

THIS GLASS IS ALSO AVAILABLE
WITH CALIBRATION MARK.



Neat Glass



Rocks Glass



Double Rocks Glass



Highball Glass

ITEM	Item no.: fine crystal machine-made	0417/01	Item no.: fine crystal machine-made	0417/02	Item no.: fine crystal machine-made	0417/07	Item no.: fine crystal machine-made	0417/04
	Height/glass:	77 mm	Height/glass:	83 mm	Height/glass:	103 mm	Height/glass:	154 mm
	Capacity/glass:	174 ccm	Capacity/glass:	283 ccm	Capacity/glass:	370 ccm	Capacity/glass:	310 ccm
	Design:	2019	Design:	2019	Design:	2022	Design:	2019
PACKAGING	Pieces/Bill unit:	1	Pieces/Bill unit:	1	Pieces/Bill unit:	1	Pieces/Bill unit:	1
TYPE AND QUANTITY	Bill units/MP:	12	Bill units/MP:	12	Bill units/MP:	12	Bill units/MP:	12
BILL UNIT	Length:	306 mm	Length:	356 mm	Length:	355 mm	Length:	292 mm
DIMENSIONS	Width:	230 mm	Width:	266 mm	Width:	265 mm	Width:	219 mm
	Height:	96 mm	Height:	103 mm	Height:	115 mm	Height:	174 mm
	Weight:	2936 gr	Weight:	4041 gr	Weight:	4915 gr	Weight:	5395 gr
EURO PALLET	Bill units/pallet:	1440	Bill units/pallet:	1080	Bill units/pallet:	1152	Bill units/pallet:	936
	Bill units/layer:	144	Bill units/layer:	108	Bill units/layer:	96	Bill units/layer:	156
	Layers/pallet:	10	Layers/pallet:	10	Layers/pallet:	12	Layers/pallet:	6
CONTAINER PALLET	Bill units/pallet:	2304	Bill units/pallet:	1716	Bill units/pallet:	1452	Bill units/pallet:	1296
HIGH CUBE	Bill units/layer:	192	Bill units/layer:	156	Bill units/layer:	132	Bill units/layer:	216
	Layers/pallet:	12	Layers/pallet:	11	Layers/pallet:	11	Layers/pallet:	6
EAN								
BILL UNIT	9 006206 528752		9 006206 528769		9 006206 323975		9 006206 528783	



Fizz Glass





Nick & Nora Glass



Nick & Nora Glass Large



Sour Glass

ITEM	Item no.: 0417/03 fine crystal machine-made	Item no.: 0417/05 fine crystal machine-made	Item no.: 0417/08 fine crystal machine-made	Item no.: 0417/06 fine crystal machine-made
	Height/glass: 163 mm Capacity/glass: 265 ccm Design: 2019	Height/glass: 153 mm Capacity/glass: 140 ccm Design: 2019	Height/glass: 177 mm Capacity/glass: 198 ccm Design: 2023	Height/glass: 158 mm Capacity/glass: 217 ccm Design: 2019
PACKAGING TYPE AND QUANTITY	Pieces/Bill unit: 1 Bill units/MP: 12	Pieces/Bill unit: 1 Bill units/MP: 12	Pieces/Bill unit: 1 Bill units/MP: 12	Pieces/Bill unit: 1 Bill units/MP: 12
BILL UNIT DIMENSIONS	Length: 267 mm Width: 199 mm Height: 179 mm Weight: 5136 gr	Length: 334 mm Width: 245 mm Height: 160 mm Weight: 1586 gr	Length: 348 mm Width: 255 mm Height: 183 mm Weight: 1849 gr	Length: 424 mm Width: 315 mm Height: 179 mm Weight: 2065 gr
EURO PALLET	Bill units/pallet: 1020 Bill units/layer: 204 Layers/pallet: 5	Bill units/pallet: 1440 Bill units/layer: 120 Layers/pallet: 12	Bill units/pallet: 1080 Bill units/layer: 108 Layers/pallet: 10	Bill units/pallet: 720 Bill units/layer: 72 Layers/pallet: 10
CONTAINER PALLET HIGH CUBE	Bill units/pallet: 1152 Bill units/layer: 288 Layers/pallet: 4	Bill units/pallet: 2352 Bill units/layer: 168 Layers/pallet: 14	Bill units/pallet: 1872 Bill units/layer: 156 Layers/pallet: 12	Bill units/pallet: 1404 Bill units/layer: 108 Layers/pallet: 13
EAN BILL UNIT	 9 006206 528776	 9 006206 528905	 9 006206 325849	 9 006206 528912







Sour Glass Optic



Coffee Glass



Mixing Glass

ITEM	Item no.: 0417/09 fine crystal machine-made Height/glass: 165 mm Capacity/glass: 215 ccm Design: 2023	Item no.: 0417/10 fine crystal machine-made Height/glass: 63 mm Capacity/glass: 90 ccm Design: 2023	Item no.: 0417/23 fine crystal machine-made Height/glass: 176 mm Capacity/glass: 650 ccm Design: 2019
PACKAGING TYPE AND QUANTITY	Pieces/Bill unit: 1 Bill units/MP: 12	Pieces/Bill unit: 1 Bill units/MP: 12	Pieces/Bill unit: 1 Bill units/MP: 4
BILL UNIT DIMENSIONS	Length: 402 mm Width: 297 mm Height: 176 mm Weight: 2012 gr	Length: 272 mm Width: 205 mm Height: 75 mm Weight: 1624 gr	Length: 92 mm Width: 92 mm Height: 189 mm Weight: 884 gr
EURO PALLET	Bill units/pallet: 720 Bill units/layer: 72 Layers/pallet: 10	Bill units/pallet: 3420 Bill units/layer: 180 Layers/pallet: 19	Bill units/pallet: 480 Bill units/layer: 96 Layers/pallet: 5
CONTAINER PALLET HIGH CUBE	Bill units/pallet: 1440 Bill units/layer: 120 Layers/pallet: 12	Bill units/pallet: 4032 Bill units/layer: 252 Layers/pallet: 16	Bill units/pallet: 600 Bill units/layer: 120 Layers/pallet: 5
EAN BILL UNIT	 9 006206 325900	 9 006206 326105	 9 006206 529988



Magnum







Red Wine



Champagne Glass



White Wine

ITEM	Item no.: 0480/90 fine crystal machine-made Height/glass: 201 mm Capacity/glass: 530 ccm Design: 2007	Item no.: 0480/00 fine crystal machine-made Height/glass: 187 mm Capacity/glass: 350 ccm Design: 2007	Item no.: 0480/08 fine crystal machine-made Height/glass: 224 mm Capacity/glass: 290 ccm Design: 2007	Item no.: 0480/05 fine crystal machine-made Height/glass: 180 mm Capacity/glass: 280 ccm Design: 2007
PACKAGING TYPE AND QUANTITY	Pieces/Bill unit: 1 Bill units/MP: 12	Pieces/Bill unit: 1 Bill units/MP: 12	Pieces/Bill unit: 1 Bill units/MP: 12	Pieces/Bill unit: 1 Bill units/MP: 12
BILL UNIT DIMENSIONS	Length: 387 mm Width: 284 mm Height: 206 mm Weight: 2288 gr	Length: 335 mm Width: 248 mm Height: 192 mm Weight: 1981 gr	Length: 307 mm Width: 228 mm Height: 239 mm Weight: 1972 gr	Length: 311 mm Width: 230 mm Height: 186 mm Weight: 1756 gr
EURO PALLET	Bill units/pallet: 864 Bill units/layer: 96 Layers/pallet: 9	Bill units/pallet: 1200 Bill units/layer: 120 Layers/pallet: 10	Bill units/pallet: 1152 Bill units/layer: 144 Layers/pallet: 8	Bill units/pallet: 1440 Bill units/layer: 144 Layers/pallet: 10
CONTAINER PALLET HIGH CUBE	Bill units/pallet: 1452 Bill units/layer: 132 Layers/pallet: 11	Bill units/pallet: 2016 Bill units/layer: 168 Layers/pallet: 12	Bill units/pallet: 1944 Bill units/layer: 216 Layers/pallet: 9	Bill units/pallet: 2304 Bill units/layer: 192 Layers/pallet: 12
EAN BILL UNIT	 9 006206 513161	 9 006206 513178	 9 006206 513192	 9 006206 513185



Red Wine







Mise en place



White Wine



Champagne Flute

ITEM	Item no.: 0489/0 fine crystal machine-made Height/glass: 224 mm Capacity/glass: 560 ccm Design: 2010	Item no.: 0489/05 fine crystal machine-made Height/glass: 217 mm Capacity/glass: 455 ccm Design: 2024	Item no.: 0489/01 fine crystal machine-made Height/glass: 205 mm Capacity/glass: 340 ccm Design: 2010	Item no.: 0489/48 fine crystal machine-made Height/glass: 224 mm Capacity/glass: 212 ccm Design: 2015
PACKAGING TYPE AND QUANTITY	Pieces/Bill unit: 1 Bill units/MP: 12	Pieces/Bill unit: 1 Bill units/MP: 12	Pieces/Bill unit: 1 Bill units/MP: 12	Pieces/Bill unit: 1 Bill units/MP: 12
BILL UNIT DIMENSIONS	Length: 367 mm Width: 271 mm Height: 230 mm Weight: 2480 gr	Length: 359 mm Width: 264 mm Height: 223 mm Weight: 2290 gr	Length: 339 mm Width: 246 mm Height: 218 mm Weight: 2140 gr	Length: 337 mm Width: 251 mm Height: 238 mm Weight: 1990 gr
EURO PALLET	Bill units/pallet: 768 Bill units/layer: 96 Layers/pallet: 8	Bill units/pallet: 864 Bill units/layer: 108 Layers/pallet: 8	Bill units/pallet: 960 Bill units/layer: 120 Layers/pallet: 8	Bill units/pallet: 960 Bill units/layer: 120 Layers/pallet: 8
CONTAINER PALLET HIGH CUBE	Bill units/pallet: 1320 Bill units/layer: 132 Layers/pallet: 10	Bill units/pallet: 1440 Bill units/layer: 144 Layers/pallet: 10	Bill units/pallet: 1680 Bill units/layer: 168 Layers/pallet: 10	Bill units/pallet: 1512 Bill units/layer: 168 Layers/pallet: 9
EAN BILL UNIT	 9 006206 515820	 9 006206 327089	 9 006206 515837	 9 006206 524273

THIS GLASS IS ALSO AVAILABLE WITH CALIBRATION MARK.

THIS GLASS IS ALSO AVAILABLE WITH CALIBRATION MARK.

THIS GLASS IS ALSO AVAILABLE WITH CALIBRATION MARK.

NO ORDER VOLUME DISCOUNT EXCLUDED FROM PROMOTIONS

degustazione



Tumbler

ITEM	Item no.: 0489/41 fine crystal machine-made
	Height/glass: 118 mm Capacity/glass: 570 ccm Design: 2014
PACKAGING	Pieces/Bill unit: 1
TYPE AND QUANTITY	Bill units/MP: 12
BILL UNIT	Length: 403 mm
DIMENSIONS	Width: 299 mm
	Height: 123 mm
	Weight: 1666 gr
EURO PALLET	Bill units/pallet: 1080
	Bill units/layer: 72
	Layers/pallet: 15
CONTAINER PALLET	Bill units/pallet: 2160
HIGH CUBE	Bill units/layer: 120
	Layers/pallet: 18
EAN	
BILL UNIT	

RIEDEL TUMBLER COLLECTION
RESTAURANT



Optical „O“
Whisky



Optical „O“
Longdrink



Optical „O“
All Purpose Glass



RIEDEL Shadows
Tumbler



ITEM	Item no.: 0512/05 fine crystal machine-made Height/glass: 96 mm Capacity/glass: 337 ccm Design: 2018	Item no.: 0512/90 fine crystal machine-made Height/glass: 113 mm Capacity/glass: 580 ccm Design: 2018	Item no.: 0512/67 fine crystal machine-made Height/glass: 124 mm Capacity/glass: 765 ccm Design: 2019	Item no.: 0512/0255 fine crystal machine-made Height/glass: 102 mm Capacity/glass: 323 ccm Design: 2019
PACKAGING TYPE AND QUANTITY	Pieces/Bill unit: 1 Bill units/MP: 12	Pieces/Bill unit: 1 Bill units/MP: 12	Pieces/Bill unit: 1 Bill units/MP: 12	Pieces/Bill unit: 1 Bill units/MP: 12
BILL UNIT DIMENSIONS	Length: 343 mm Width: 254 mm Height: 111 mm Weight: 1444 gr	Length: 404 mm Width: 308 mm Height: 140 mm Weight: 2034 gr	Length: 475 mm Width: 354 mm Height: 133 mm Weight: 1932 gr	Length: 354 mm Width: 265 mm Height: 124 mm Weight: 4731 gr
EURO PALLET	Bill units/pallet: 1920 Bill units/layer: 120 Layers/pallet: 16	Bill units/pallet: 936 Bill units/layer: 72 Layers/pallet: 13	Bill units/pallet: 672 Bill units/layer: 48 Layers/pallet: 14	Bill units/pallet: 972 Bill units/layer: 108 Layers/pallet: 9
CONTAINER PALLET HIGH CUBE	Bill units/pallet: 3360 Bill units/layer: 168 Layers/pallet: 20	Bill units/pallet: 1728 Bill units/layer: 108 Layers/pallet: 16	Bill units/pallet: 1428 Bill units/layer: 84 Layers/pallet: 17	Bill units/pallet: 1404 Bill units/layer: 156 Layers/pallet: 9
EAN BILL UNIT	 9 006206 527465	 9 006206 527458	 9 006206 530052	 9 006206 530137



RIEDEL Fire
Whisky



RIEDEL Fire
Longdrink

ITEM	Item no.: 0512/02S1 fine crystal machine-made Height/glass: 98 mm Capacity/glass: 295 ccm Design: 2018	Item no.: 0512/04S1 fine crystal machine-made Height/glass: 151 mm Capacity/glass: 375 ccm Design: 2018
PACKAGING TYPE AND QUANTITY	Pieces/Bill unit: 1 Bill units/MP: 12	Pieces/Bill unit: 1 Bill units/MP: 12
BILL UNIT DIMENSIONS	Length: 398 mm Width: 296 mm Height: 133 mm Weight: 4132 gr	Length: 350 mm Width: 267 mm Height: 190 mm Weight: 5684 gr
EURO PALLET	Bill units/pallet: 1344 Bill units/layer: 96 Layers/pallet: 14	Bill units/pallet: 960 Bill units/layer: 96 Layers/pallet: 10
CONTAINER PALLET HIGH CUBE	Bill units/pallet: 1680 Bill units/layer: 120 Layers/pallet: 14	Bill units/pallet: 1092 Bill units/layer: 156 Layers/pallet: 7
EAN BILL UNIT	 9 006206 527472	 9 006206 527502





RIEDEL Fire Whisky
Baby Blue



RIEDEL Fire Whisky
Red



RIEDEL Fire Whisky
Yellow



RIEDEL Fire Whisky
Green

ITEM	Item no.: 0512/02B fine crystal machine-made Height/glass: 98 mm Capacity/glass: 295 ccm Design: 2019	Item no.: 0512/02R fine crystal machine-made Height/glass: 98 mm Capacity/glass: 295 ccm Design: 2019	Item no.: 0512/02Y fine crystal machine-made Height/glass: 98 mm Capacity/glass: 295 ccm Design: 2019	Item no.: 0512/02G fine crystal machine-made Height/glass: 98 mm Capacity/glass: 295 ccm Design: 2019
PACKAGING TYPE AND QUANTITY	Pieces/Bill unit: 1 Bill units/MP: 12	Pieces/Bill unit: 1 Bill units/MP: 12	Pieces/Bill unit: 1 Bill units/MP: 12	Pieces/Bill unit: 1 Bill units/MP: 12
BILL UNIT DIMENSIONS	Length: 398 mm Width: 296 mm Height: 133 mm Weight: 3922 gr	Length: 398 mm Width: 296 mm Height: 133 mm Weight: 3922 gr	Length: 398 mm Width: 296 mm Height: 133 mm Weight: 3922 gr	Length: 398 mm Width: 296 mm Height: 133 mm Weight: 3922 gr
EURO PALLET	Bill units/pallet: 1344 Bill units/layer: 96 Layers/pallet: 14	Bill units/pallet: 1344 Bill units/layer: 96 Layers/pallet: 14	Bill units/pallet: 1344 Bill units/layer: 96 Layers/pallet: 14	Bill units/pallet: 1344 Bill units/layer: 96 Layers/pallet: 14
CONTAINER PALLET HIGH CUBE	Bill units/pallet: 1680 Bill units/layer: 120 Layers/pallet: 14	Bill units/pallet: 1680 Bill units/layer: 120 Layers/pallet: 14	Bill units/pallet: 1680 Bill units/layer: 120 Layers/pallet: 14	Bill units/pallet: 1680 Bill units/layer: 120 Layers/pallet: 14
EAN BILL UNIT	 9 006206 530083	 9 006206 530090	 9 006206 530106	 9 006206 530113

**NO ORDER VOLUME DISCOUNT
EXCLUDED FROM PROMOTIONS**





Highball



Double Old Fashioned



Single Old Fashioned

ITEM	Item no.: fine crystal machine-made	0419/04	Item no.: fine crystal machine-made	0419/02	Item no.: fine crystal machine-made	0419/01
	Height/glass:	149 mm	Height/glass:	97 mm	Height/glass:	93 mm
	Capacity/glass:	350 ccm	Capacity/glass:	370 ccm	Capacity/glass:	290 ccm
	Design:	2014	Design:	2014	Design:	2014
PACKAGING	Pieces/Bill unit:	1	Pieces/Bill unit:	1	Pieces/Bill unit:	1
TYPE AND QUANTITY	Bill units/MP:	12	Bill units/MP:	12	Bill units/MP:	12
BILL UNIT	Length:	308 mm	Length:	365 mm	Length:	332 mm
DIMENSIONS	Width:	233 mm	Width:	276 mm	Width:	252 mm
	Height:	164 mm	Height:	111 mm	Height:	108 mm
	Weight:	4519 gr	Weight:	3848 gr	Weight:	3171 gr
EURO PALLET	Bill units/pallet:	1296	Bill units/pallet:	960	Bill units/pallet:	1920
	Bill units/layer:	144	Bill units/layer:	96	Bill units/layer:	120
	Layers/pallet:	9	Layers/pallet:	10	Layers/pallet:	16
CONTAINER PALLET	Bill units/pallet:	1536	Bill units/pallet:	1716	Bill units/pallet:	2184
HIGH CUBE	Bill units/layer:	192	Bill units/layer:	132	Bill units/layer:	168
	Layers/pallet:	8	Layers/pallet:	13	Layers/pallet:	13
EAN	 9 006206 522842		 9 006206 522828		 9 006206 522811	
BILL UNIT						





Cabernet/Merlot



Pinot Noir



Riesling/Sauvignon/Champagne Glass

ITEM	Item no.: 0789/0 fine crystal machine-made Height/glass: 121 mm Capacity/glass: 675 ccm Design: 2021	Item no.: 0789/07 fine crystal machine-made Height/glass: 121 mm Capacity/glass: 630 ccm Design: 2021	Item no.: 0789/15 fine crystal machine-made Height/glass: 109 mm Capacity/glass: 440 ccm Design: 2021
PACKAGING TYPE AND QUANTITY	Pieces/Bill unit: 1 Bill units/MP: 12	Pieces/Bill unit: 1 Bill units/MP: 12	Pieces/Bill unit: 1 Bill units/MP: 12
BILL UNIT DIMENSIONS	Length: 421 mm Width: 312 mm Height: 126 mm Weight: 1800 gr	Length: 309 mm Width: 204 mm Height: 123 mm Weight: 1800 gr	Length: 382 mm Width: 282 mm Height: 114 mm Weight: 1507 gr
EURO PALLET	Bill units/pallet: 1008 Bill units/layer: 72 Layers/pallet: 14	Bill units/pallet: 1008 Bill units/layer: 72 Layers/pallet: 14	Bill units/pallet: 1536 Bill units/layer: 96 Layers/pallet: 16
CONTAINER PALLET HIGH CUBE	Bill units/pallet: 1836 Bill units/layer: 108 Layers/pallet: 17	Bill units/pallet: 1836 Bill units/layer: 108 Layers/pallet: 17	Bill units/pallet: 2508 Bill units/layer: 132 Layers/pallet: 19
EAN BILL UNIT	 9 006206 322077	 9 006206 322091	 9 006206 322084

While supplies last.

While supplies last.

While supplies last.



Syrah/Shiraz





Cabernet/Merlot



Pinot Noir/Nebbiolo



Champagne Glass

ITEM	Item no.: 0412/30 fine crystal machine-made Height/glass: 132 mm Capacity/glass: 620 ccm Design: 2003	Item no.: 0412/0 fine crystal machine-made Height/glass: 121 mm Capacity/glass: 620 ccm Design: 2003	Item no.: 0412/07 fine crystal machine-made Height/glass: 110 mm Capacity/glass: 690 ccm Design: 2003	Item no.: 0412/28 fine crystal machine-made Height/glass: 122 mm Capacity/glass: 264 ccm Design: 2014
PACKAGING TYPE AND QUANTITY	Pieces/Bill unit: 1 Bill units/MP: 12	Pieces/Bill unit: 1 Bill units/MP: 12	Pieces/Bill unit: 1 Bill units/MP: 12	Pieces/Bill unit: 1 Bill units/MP: 12
BILL UNIT DIMENSIONS	Length: 404 mm Width: 308 mm Height: 151 mm Weight: 1787 gr	Length: 404 mm Width: 308 mm Height: 140 mm Weight: 1770 gr	Length: 475 mm Width: 354 mm Height: 133 mm Weight: 1356 gr	Length: 267 mm Width: 202 mm Height: 135 mm Weight: 1322 gr
EURO PALLET	Bill units/pallet: 864 Bill units/layer: 72 Layers/pallet: 12	Bill units/pallet: 936 Bill units/layer: 72 Layers/pallet: 13	Bill units/pallet: 672 Bill units/layer: 48 Layers/pallet: 14	Bill units/pallet: 2520 Bill units/layer: 180 Layers/pallet: 14
CONTAINER PALLET HIGH CUBE	Bill units/pallet: 1620 Bill units/layer: 108 Layers/pallet: 15	Bill units/pallet: 1728 Bill units/layer: 108 Layers/pallet: 16	Bill units/pallet: 1428 Bill units/layer: 84 Layers/pallet: 17	Bill units/pallet: 4896 Bill units/layer: 288 Layers/pallet: 17
EAN BILL UNIT	 9 006206 512225	 9 006206 512232	 9 006206 512249	 9 006206 522354



Riesling/Sauvignon Blanc



Viognier/Chardonnay



Oaked Chardonnay

Spirits/Fortified Wines/
Cask Aged Brandies

ITEM	Item no.: 0412/15 fine crystal machine-made Height/glass: 108 mm Capacity/glass: 375 ccm Design: 2003	Item no.: 0412/05 fine crystal machine-made Height/glass: 96 mm Capacity/glass: 335 ccm Design: 2003	Item no.: 0412/97 fine crystal machine-made Height/glass: 94 mm Capacity/glass: 580 ccm Design: 2003	Item no.: 0412/60 fine crystal machine-made Height/glass: 90 mm Capacity/glass: 235 ccm Design: 2004
PACKAGING TYPE AND QUANTITY	Pieces/Bill unit: 1 Bill units/MP: 12	Pieces/Bill unit: 1 Bill units/MP: 12	Pieces/Bill unit: 1 Bill units/MP: 12	Pieces/Bill unit: 1 Bill units/MP: 12
BILL UNIT DIMENSIONS	Length: 343 mm Width: 254 mm Height: 111 mm Weight: 1492 gr	Length: 343 mm Width: 254 mm Height: 111 mm Weight: 1444 gr	Length: 475 mm Width: 354 mm Height: 133 mm Weight: 1656 gr	Length: 300 mm Width: 230 mm Height: 108 mm Weight: 1299 gr
EURO PALLET	Bill units/pallet: 1920 Bill units/layer: 120 Layers/pallet: 16	Bill units/pallet: 1920 Bill units/layer: 120 Layers/pallet: 16	Bill units/pallet: 672 Bill units/layer: 48 Layers/pallet: 14	Bill units/pallet: 2652 Bill units/layer: 156 Layers/pallet: 17
CONTAINER PALLET HIGH CUBE	Bill units/pallet: 3360 Bill units/layer: 168 Layers/pallet: 20	Bill units/pallet: 3360 Bill units/layer: 168 Layers/pallet: 20	Bill units/pallet: 1428 Bill units/layer: 84 Layers/pallet: 17	Bill units/pallet: 4536 Bill units/layer: 216 Layers/pallet: 21
EAN BILL UNIT	 9 006206 512270	 9 006206 512263	 9 006206 512256	 9 006206 512591





New World Pinot Noir

ITEM	Item no.: 0412/67 fine crystal machine-made Height/glass: 124 mm Capacity/glass: 760 ccm Design: 2014
PACKAGING	Pieces/Bill unit: 1
TYPE AND QUANTITY	Bill units/MP: 12
BILL UNIT	Length: 475 mm
DIMENSIONS	Width: 354 mm
	Height: 133 mm
	Weight: 1932 gr
EURO PALLET	Bill units/pallet: 672
	Bill units/layer: 48
	Layers/pallet: 14
CONTAINER PALLET	Bill units/pallet: 1428
HIGH CUBE	Bill units/layer: 84
	Layers/pallet: 17
EAN BILL UNIT	 9 006206 522583



Viognier/Chardonnay
Dawn-Red





Viognier/Chardonnay
Spring-Green



Viognier/Chardonnay
Easter-Yellow



Viognier/Chardonnay
Baby-Blue

ITEM	Item no.: 0412/05r fine crystal machine-made Height/glass: 96 mm Capacity/glass: 335 ccm Design: 2014	Item no.: 0412/05g fine crystal machine-made Height/glass: 96 mm Capacity/glass: 335 ccm Design: 2014	Item no.: 0412/05y fine crystal machine-made Height/glass: 96 mm Capacity/glass: 335 ccm Design: 2014	Item no.: 0412/05b fine crystal machine-made Height/glass: 96 mm Capacity/glass: 335 ccm Design: 2014
PACKAGING TYPE AND QUANTITY	Pieces/Bill unit: 1 Bill units/MP: 12	Pieces/Bill unit: 1 Bill units/MP: 12	Pieces/Bill unit: 1 Bill units/MP: 12	Pieces/Bill unit: 1 Bill units/MP: 12
BILL UNIT DIMENSIONS	Length: 343 mm Width: 254 mm Height: 111 mm Weight: 1444 gr	Length: 343 mm Width: 254 mm Height: 111 mm Weight: 1444 gr	Length: 343 mm Width: 254 mm Height: 111 mm Weight: 1444 gr	Length: 343 mm Width: 254 mm Height: 111 mm Weight: 1444 gr
EURO PALLET	Bill units/pallet: 1920 Bill units/layer: 120 Layers/pallet: 16	Bill units/pallet: 1920 Bill units/layer: 120 Layers/pallet: 16	Bill units/pallet: 1920 Bill units/layer: 120 Layers/pallet: 16	Bill units/pallet: 1920 Bill units/layer: 120 Layers/pallet: 16
CONTAINER PALLET HIGH CUBE	Bill units/pallet: 3360 Bill units/layer: 168 Layers/pallet: 20	Bill units/pallet: 3360 Bill units/layer: 168 Layers/pallet: 20	Bill units/pallet: 3360 Bill units/layer: 168 Layers/pallet: 20	Bill units/pallet: 3360 Bill units/layer: 168 Layers/pallet: 20
EAN BILL UNIT	 9 006206 523498	 9 006206 523474	 9 006206 523481	 9 006206 523504

**NO ORDER VOLUME DISCOUNT
EXCLUDED FROM PROMOTIONS**



Viognier/Chardonnay
Violet



Viognier/Chardonnay
Cinnabar-Red



Viognier/Chardonnay
Orange



Viognier/Chardonnay
Azure-Blue

ITEM	Item no.: 0412/05v fine crystal machine-made Height/glass: 96 mm Capacity/glass: 335 ccm Design: 2017	Item no.: 0412/05c fine crystal machine-made Height/glass: 96 mm Capacity/glass: 335 ccm Design: 2017	Item no.: 0412/05o fine crystal machine-made Height/glass: 96 mm Capacity/glass: 335 ccm Design: 2017	Item no.: 0412/05a fine crystal machine-made Height/glass: 96 mm Capacity/glass: 335 ccm Design: 2017
PACKAGING TYPE AND QUANTITY	Pieces/Bill unit: 1 Bill units/MP: 12	Pieces/Bill unit: 1 Bill units/MP: 12	Pieces/Bill unit: 1 Bill units/MP: 12	Pieces/Bill unit: 1 Bill units/MP: 12
BILL UNIT DIMENSIONS	Length: 343 mm Width: 254 mm Height: 111 mm Weight: 1444 gr	Length: 343 mm Width: 254 mm Height: 111 mm Weight: 1444 gr	Length: 343 mm Width: 254 mm Height: 111 mm Weight: 1444 gr	Length: 343 mm Width: 254 mm Height: 111 mm Weight: 1444 gr
EURO PALLET	Bill units/pallet: 1920 Bill units/layer: 120 Layers/pallet: 16	Bill units/pallet: 1920 Bill units/layer: 120 Layers/pallet: 16	Bill units/pallet: 1920 Bill units/layer: 120 Layers/pallet: 16	Bill units/pallet: 1920 Bill units/layer: 120 Layers/pallet: 16
CONTAINER PALLET HIGH CUBE	Bill units/pallet: 3360 Bill units/layer: 168 Layers/pallet: 20	Bill units/pallet: 3360 Bill units/layer: 168 Layers/pallet: 20	Bill units/pallet: 3360 Bill units/layer: 168 Layers/pallet: 20	Bill units/pallet: 3360 Bill units/layer: 168 Layers/pallet: 20
EAN BILL UNIT	 9 006206 525942	 9 006206 525928	 9 006206 525935	 9 006206 525911



**NO ORDER VOLUME DISCOUNT
EXCLUDED FROM PROMOTIONS**



Red Wine



White Wine





ITEM	Item no.: 0413/30 fine crystal machine-made Height/glass: 120 mm Capacity/glass: 580 ccm Design: 2010	Item no.: 0413/33 fine crystal machine-made Height/glass: 103 mm Capacity/glass: 380 ccm Design: 2010
PACKAGING TYPE AND QUANTITY	Pieces/Bill unit: 1 Bill units/MP: 12	Pieces/Bill unit: 1 Bill units/MP: 12
BILL UNIT DIMENSIONS	Length: 394 mm Width: 296 mm Height: 140 mm Weight: 1850 gr	Length: 343 mm Width: 254 mm Height: 111 mm Weight: 1492 gr
EURO PALLET	Bill units/pallet: 1248 Bill units/layer: 96 Layers/pallet: 13	Bill units/pallet: 1920 Bill units/layer: 120 Layers/pallet: 16
CONTAINER PALLET HIGH CUBE	Bill units/pallet: 1920 Bill units/layer: 120 Layers/pallet: 16	Bill units/pallet: 3360 Bill units/layer: 168 Layers/pallet: 20
EAN BILL UNIT	 9 006206 516100	 9 006206 516117



RIEDEL Resort
Highball



RIEDEL Resort
Double Rocks

ITEM	Item no.: fine crystal Tritan™ from eastman 	0417/94	Item no.: fine crystal Tritan™ from eastman 	0417/97
	Height/glass:	156 mm	Height/glass:	103 mm
	Capacity/glass:	447 ccm	Capacity/glass:	411 ccm
	Design:	2023	Design:	2023
PACKAGING	Pieces/Bill unit:	1	Pieces/Bill unit:	1
TYPE AND QUANTITY	Bill units/MP:	6	Bill units/MP:	6
BILL UNIT	Length:	234 mm	Length:	267 mm
DIMENSIONS	Width:	158 mm	Width:	180 mm
	Height:	166 mm	Height:	114 mm
	Weight:	1361 gr	Weight:	979 gr
EURO PALLET	Bill units/pallet:	1584	Bill units/pallet:	1632
	Bill units/layer:	144	Bill units/layer:	102
	Layers/pallet:	11	Layers/pallet:	16
CONTAINER PALLET	Bill units/pallet:	2496	Bill units/pallet:	2622
HIGH CUBE	Bill units/layer:	192	Bill units/layer:	138
	Layers/pallet:	13	Layers/pallet:	19
EAN		9 006206 326969		9 006206 326952
BILL UNIT				

tritan™
from eastman



PERFORMANCE

- Durability
- Shatter resistance
- Dishwasher durability



QUALITY

- Clarity
- Style



SAFETY

- BPA free
- Food contact safety
- EA free

**NO ORDER VOLUME DISCOUNT
EXCLUDED FROM PROMOTIONS**







Amadeo Double Magnum Decanter



Horn Decanter

ITEM	Item no.:	1756/80	Item no.:	2014/02
	fine crystal		fine crystal	
	handmade		handmade	
	Height:	680 mm	Height:	370 mm
PACKAGING TYPE AND QUANTITY	Capacity:	3000 ccm	Capacity:	750 ccm
	Design:	2014	Design:	2014
	Pieces/Bill unit:	1	Pieces/Bill unit:	1
	Bill units/MP:	1	Bill units/MP:	1
BILL UNIT DIMENSIONS	Length:	412 mm	Length:	303 mm
	Width:	207 mm	Width:	183 mm
	Height:	755 mm	Height:	458 mm
	Weight:	3000 gr	Weight:	1207 gr
MASTERPACK DIMENSIONS	Length:	422 mm	Length:	314 mm
	Width:	218 mm	Width:	194 mm
	Height:	766 mm	Height:	464 mm
	Weight:	3398 gr	Weight:	1327 gr
EURO PALLET	Bill units/pallet:	20	Bill units/pallet:	56
	Bill units/layer:	5	Bill units/layer:	14
	Layers/pallet:	4	Layers/pallet:	4
CONTAINER PALLET HIGH CUBE	Bill units/pallet:	36	Bill units/pallet:	100
	Bill units/layer:	12	Bill units/layer:	20
	Layers/pallet:	3	Layers/pallet:	5
EAN BILL UNIT	 9 006206 214051		 9 006206 311743	

R.Q. (RESTAURANT QUALITY) OF HANDMADE DECANTERS ONLY UPON AVAILABILITY.

Kindly avoid overpouring the decanter. It's designed for specific fillings: 0.75L for regular, 1.5L for magnum, and 3L for double magnum. Do keep in mind that sizes may vary due to the unique handmade nature of these decanters but they always hold the specified filling quantity.



Black Tie Decanter



RIEDEL Amadeo
Magnum Decanter Optic



RIEDEL Amadeo
Luminance Decanter



RIEDEL Amadeo
Phyllon Decanter

ITEM	Item no.: fine crystal handmade	4100/23	Item no.: fine crystal handmade	1756/24	Item no.: fine crystal handmade	1756/13L	Item no.: fine crystal handmade	1756/13P
	Height:	420 mm	Height:	420 mm	Height:	350 mm	Height:	350 mm
	Capacity:	750 ccm	Capacity:	1500 ccm	Capacity:	750 ccm	Capacity:	750 ccm
	Design:	2009	Design:	2024	Design:	2024	Design:	2024
PACKAGING	Pieces/Bill unit:	1	Pieces/Bill unit:	1	Pieces/Bill unit:	1	Pieces/Bill unit:	1
TYPE AND QUANTITY	Bill units/MP:	1	Bill units/MP:	1	Bill units/MP:	1	Bill units/MP:	1
BILL UNIT	Length:	279 mm	Length:	279 mm	Length:	397 mm	Length:	397 mm
DIMENSIONS	Width:	275 mm	Width:	275 mm	Width:	229 mm	Width:	229 mm
	Height:	551 mm	Height:	551 mm	Height:	129 mm	Height:	129 mm
	Weight:	1246 gr	Weight:	1376 gr	Weight:	1012 gr	Weight:	1012 gr
MASTERPACK	Length:	290 mm	Length:	290 mm	Length:	397 mm	Length:	397 mm
DIMENSIONS	Width:	281 mm	Width:	281 mm	Width:	234 mm	Width:	234 mm
	Height:	556 mm	Height:	556 mm	Height:	135 mm	Height:	135 mm
	Weight:	1618 gr	Weight:	1748 gr	Weight:	1144 gr	Weight:	1144 gr
EURO PALLET	Bill units/pallet:	24	Bill units/pallet:	24	Bill units/pallet:	91	Bill units/pallet:	91
	Bill units/layer:	4	Bill units/layer:	4	Bill units/layer:	7	Bill units/layer:	7
	Layers/pallet:	6	Layers/pallet:	6	Layers/pallet:	13	Layers/pallet:	13
CONTAINER PALLET	Bill units/pallet:	48	Bill units/pallet:	48	Bill units/pallet:	208	Bill units/pallet:	208
HIGH CUBE	Bill units/layer:	6	Bill units/layer:	6	Bill units/layer:	13	Bill units/layer:	13
	Layers/pallet:	8	Layers/pallet:	8	Layers/pallet:	16	Layers/pallet:	16
EAN								
BILL UNIT	9 006206 311439		9 006206 327010		9 006206 326990		9 006206 327003	

DECANTERS



**LIMITED EDITION
OF 300 PIECES.**

**LIMITED EDITION
OF 300 PIECES.**

Limited Editions: TG reserves the right to offer glassware marked as "Limited Edition" in a certain amount and for a certain time period and under certain allocation criteria to Customer.





Decanter Tyrol



Horse Decanter



Black Tie Face To Face Decanter

ITEM	Item no.:	1405/13	Item no.:	4101/13	Item no.:	4100/13
	fine crystal handmade		fine crystal handmade		fine crystal handmade	
	Height:	192 mm	Height:	600 mm	Height:	600 mm
	Capacity:	750 ccm	Capacity:	750 ccm	Capacity:	750 ccm
	Design:	2007	Design:	2014	Design:	2009
PACKAGING TYPE AND QUANTITY	Pieces/Bill unit:	1	Pieces/Bill unit:	1	Pieces/Bill unit:	1
	Bill units/MP:	1	Bill units/MP:	1	Bill units/MP:	1
BILL UNIT DIMENSIONS	Length:	279 mm	Length:	275 mm	Length:	275 mm
	Width:	275 mm	Width:	225 mm	Width:	225 mm
	Height:	551 mm	Height:	632 mm	Height:	632 mm
	Weight:	1746 gr	Weight:	1532 gr	Weight:	1532 gr
MASTERPACK DIMENSIONS	Length:	290 mm	Length:	286 mm	Length:	286 mm
	Width:	281 mm	Width:	234 mm	Width:	234 mm
	Height:	556 mm	Height:	634 mm	Height:	634 mm
	Weight:	2753 gr	Weight:	1780 gr	Weight:	1780 gr
EURO PALLET	Bill units/pallet:	24	Bill units/pallet:	30	Bill units/pallet:	30
	Bill units/layer:	4	Bill units/layer:	5	Bill units/layer:	5
	Layers/pallet:	6	Layers/pallet:	6	Layers/pallet:	6
CONTAINER PALLET HIGH CUBE	Bill units/pallet:	48	Bill units/pallet:	54	Bill units/pallet:	54
	Bill units/layer:	6	Bill units/layer:	6	Bill units/layer:	6
	Layers/pallet:	8	Layers/pallet:	9	Layers/pallet:	9
EAN BILL UNIT	 9 006206 311354		 9 006206 311798		 9 006206 311446	

CAUTION: the indented design feature of this decanter must not be used as a handle. Do not insert your hand or any item into the indented area. Cleaning beads should not be used. Carefully hand wash only.

CAUTION: the indented design feature of this decanter must not be used as a handle. Do not insert your hand or any item into the indented area. Cleaning beads should not be used. Carefully hand wash only.





Mamba Decanter



Eve Decanter

Boa Decanter

ITEM	Item no.: fine crystal handmade	1950/19	Item no.: fine crystal handmade	1950/09	Item no.: fine crystal handmade	2013/01
	Height:	325 mm	Height:	505 mm	Height:	350 mm
	Capacity:	750 ccm	Capacity:	750 ccm	Capacity:	750 ccm
	Design:	2011	Design:	2009	Design:	2013
PACKAGING	Pieces/Bill unit:	1	Pieces/Bill unit:	1	Pieces/Bill unit:	1
TYPE AND QUANTITY	Bill units/MP:	1	Bill units/MP:	1	Bill units/MP:	1
BILL UNIT	Length:	420 mm	Length:	279 mm	Length:	279 mm
DIMENSIONS	Width:	267 mm	Width:	275 mm	Width:	275 mm
	Height:	435 mm	Height:	551 mm	Height:	551 mm
	Weight:	1660 gr	Weight:	1346 gr	Weight:	1316 gr
MASTERPACK	Length:	425 mm	Length:	290 mm	Length:	290 mm
DIMENSIONS	Width:	273 mm	Width:	281 mm	Width:	281 mm
	Height:	445 mm	Height:	556 mm	Height:	556 mm
	Weight:	1887 gr	Weight:	1613 gr	Weight:	1685 gr
EURO PALLET	Bill units/pallet:	24	Bill units/pallet:	24	Bill units/pallet:	24
	Bill units/layer:	6	Bill units/layer:	4	Bill units/layer:	4
	Layers/pallet:	4	Layers/pallet:	6	Layers/pallet:	6
CONTAINER PALLET	Bill units/pallet:	45	Bill units/pallet:	48	Bill units/pallet:	48
HIGH CUBE	Bill units/layer:	9	Bill units/layer:	6	Bill units/layer:	6
	Layers/pallet:	5	Layers/pallet:	8	Layers/pallet:	8
EAN	 9 006206 311484		 9 006206 311422		 9 006206 213672	
BILL UNIT						

DECANTERS

NEW







RIEDEL Vitis Decanter

RIEDEL Winewings Decanter

Swan Decanter

Black Tie Amadeo Decanter

ITEM	Item no.: fine crystal handmade	2024/01	Item no.: fine crystal handmade	2007/02S1	Item no.: fine crystal handmade	2007/02	Item no.: fine crystal handmade	4100/83
	Height:	600 mm	Height:	600 mm	Height:	600 mm	Height:	350 mm
	Capacity:	750 ccm	Capacity:	750 ccm	Capacity:	750 ccm	Capacity:	750 ccm
	Design:	2024	Design:	2020	Design:	2008	Design:	2009
PACKAGING	Pieces/Bill unit:	1	Pieces/Bill unit:	1	Pieces/Bill unit:	1	Pieces/Bill unit:	1
TYPE AND QUANTITY	Bill units/MP:	1	Bill units/MP:	1	Bill units/MP:	1	Bill units/MP:	1
BILL UNIT	Length:	275 mm	Length:	275 mm	Length:	275 mm	Length:	303 mm
DIMENSIONS	Width:	225 mm	Width:	225 mm	Width:	225 mm	Width:	183 mm
	Height:	632 mm	Height:	632 mm	Height:	632 mm	Height:	458 mm
	Weight:	1272 gr	Weight:	1190 gr	Weight:	1162 gr	Weight:	1067 gr
MASTERPACK	Length:	286 mm	Length:	286 mm	Length:	286 mm	Length:	314 mm
DIMENSIONS	Width:	234 mm	Width:	234 mm	Width:	234 mm	Width:	194 mm
	Height:	634 mm	Height:	634 mm	Height:	634 mm	Height:	464 mm
	Weight:	1546 gr	Weight:	1464 gr	Weight:	1441 gr	Weight:	1243 gr
EURO PALLET	Bill units/pallet:	30	Bill units/pallet:	30	Bill units/pallet:	30	Bill units/pallet:	56
	Bill units/layer:	5	Bill units/layer:	5	Bill units/layer:	5	Bill units/layer:	14
	Layers/pallet:	6	Layers/pallet:	6	Layers/pallet:	6	Layers/pallet:	4
CONTAINER PALLET	Bill units/pallet:	54	Bill units/pallet:	54	Bill units/pallet:	54	Bill units/pallet:	100
HIGH CUBE	Bill units/layer:	6	Bill units/layer:	6	Bill units/layer:	6	Bill units/layer:	20
	Layers/pallet:	9	Layers/pallet:	9	Layers/pallet:	9	Layers/pallet:	5
EAN								
BILL UNIT	9 006206 327300		9 006206 313754		9 006206 311385		9 006206 311408	



reddot design award

Kindly avoid overpouring the decanter. It's designed for specific fillings: 0.75L for regular, 1.5L for magnum, and 3L for double magnum. Do keep in mind that sizes may vary due to the unique handmade nature of these decanters but they always hold the specified filling quantity.



Amadeo Decanter
Blue



Amadeo Decanter
Menta



Amadeo Decanter
Rosa



Amadeo Decanter

ITEM	Item no.:	1756/13-B	Item no.:	1756/13-M	Item no.:	1756/13-R	Item no.:	1756/13
	fine crystal handmade		fine crystal handmade		fine crystal handmade		fine crystal handmade	
	Height:	350 mm	Height:	350 mm	Height:	350 mm	Height:	350 mm
	Capacity:	750 ccm	Capacity:	750 ccm	Capacity:	750 ccm	Capacity:	750 ccm
	Design:	2022	Design:	2019	Design:	2019	Design:	2006
PACKAGING TYPE AND QUANTITY	Pieces/Bill unit:	1	Pieces/Bill unit:	1	Pieces/Bill unit:	1	Pieces/Bill unit:	1
	Bill units/MP:	1	Bill units/MP:	1	Bill units/MP:	1	Bill units/MP:	1
BILL UNIT DIMENSIONS	Length:	303 mm	Length:	303 mm	Length:	303 mm	Length:	303 mm
	Width:	183 mm	Width:	183 mm	Width:	183 mm	Width:	183 mm
	Height:	458 mm	Height:	458 mm	Height:	458 mm	Height:	458 mm
	Weight:	1097 gr	Weight:	1097 gr	Weight:	1097 gr	Weight:	1097 gr
MASTERPACK DIMENSIONS	Length:	314 mm	Length:	314 mm	Length:	314 mm	Length:	314 mm
	Width:	194 mm	Width:	194 mm	Width:	194 mm	Width:	194 mm
	Height:	464 mm	Height:	464 mm	Height:	464 mm	Height:	464 mm
	Weight:	1273 gr	Weight:	1246 gr	Weight:	1273 gr	Weight:	1217 gr
EURO PALLET	Bill units/pallet:	56	Bill units/pallet:	56	Bill units/pallet:	56	Bill units/pallet:	56
	Bill units/layer:	14	Bill units/layer:	14	Bill units/layer:	14	Bill units/layer:	14
	Layers/pallet:	4	Layers/pallet:	4	Layers/pallet:	4	Layers/pallet:	4
CONTAINER PALLET HIGH CUBE	Bill units/pallet:	100	Bill units/pallet:	100	Bill units/pallet:	100	Bill units/pallet:	100
	Bill units/layer:	20	Bill units/layer:	20	Bill units/layer:	20	Bill units/layer:	20
	Layers/pallet:	5	Layers/pallet:	5	Layers/pallet:	5	Layers/pallet:	5
EAN BILL UNIT								
	9 006206 324040		9 006206 313303		9 006206 313327		9 006206 212736	





Mamba Fatto A Mano Decanter



Ayam Decanter



Ayam Decanter
Black

ITEM	Item no.: fine crystal handmade	1950/00	Item no.: fine crystal handmade	2016/01	Item no.: fine crystal handmade	2016/02
	Height:	325 mm	Height:	287 mm	Height:	287 mm
	Capacity:	750 ccm	Capacity:	750 ccm	Capacity:	750 ccm
	Design:	2017	Design:	2016	Design:	2016
PACKAGING	Pieces/Bill unit:	1	Pieces/Bill unit:	1	Pieces/Bill unit:	1
TYPE AND QUANTITY	Bill units/MP:	1	Bill units/MP:	1	Bill units/MP:	1
BILL UNIT	Length:	420 mm	Length:	303 mm	Length:	303 mm
DIMENSIONS	Width:	267 mm	Width:	183 mm	Width:	183 mm
	Height:	435 mm	Height:	458 mm	Height:	458 mm
	Weight:	1660 gr	Weight:	1147 gr	Weight:	1147 gr
MASTERPACK	Length:	425 mm	Length:	314 mm	Length:	314 mm
DIMENSIONS	Width:	273 mm	Width:	194 mm	Width:	194 mm
	Height:	445 mm	Height:	464 mm	Height:	464 mm
	Weight:	1900 gr	Weight:	1219 gr	Weight:	1260 gr
EURO PALLET	Bill units/pallet:	24	Bill units/pallet:	56	Bill units/pallet:	56
	Bill units/layer:	6	Bill units/layer:	14	Bill units/layer:	14
	Layers/pallet:	4	Layers/pallet:	4	Layers/pallet:	4
CONTAINER PALLET	Bill units/pallet:	45	Bill units/pallet:	100	Bill units/pallet:	100
HIGH CUBE	Bill units/layer:	9	Bill units/layer:	20	Bill units/layer:	20
	Layers/pallet:	5	Layers/pallet:	5	Layers/pallet:	5
EAN	 9 006206 312788		 9 006206 312412		 9 006206 312429	
BILL UNIT						



Amadeo Fatto A Mano Decanter







Amadeo Performance Decanter



Amadeo Mini Decanter



RIEDEL Superleggero Decanter

ITEM	Item no.: fine crystal handmade	1756/00	Item no.: fine crystal handmade	1756/19	Item no.: fine crystal handmade	1756/14	Item no.: fine crystal handmade	1925/01
	Height:	350 mm	Height:	350 mm	Height:	250 mm	Height:	410 mm
	Capacity:	750 ccm	Capacity:	750 ccm	Capacity:	375 ccm	Capacity:	750 ccm
	Design:	2017	Design:	2019	Design:	2019	Design:	2015
PACKAGING	Pieces/Bill unit:	1	Pieces/Bill unit:	1	Pieces/Bill unit:	1	Pieces/Bill unit:	1
TYPE AND QUANTITY	Bill units/MP:	1	Bill units/MP:	1	Bill units/MP:	-	Bill units/MP:	1
BILL UNIT	Length:	303 mm	Length:	303 mm	Length:	291 mm	Length:	172 mm
DIMENSIONS	Width:	183 mm	Width:	183 mm	Width:	198 mm	Width:	172 mm
	Height:	458 mm	Height:	458 mm	Height:	224 mm	Height:	476 mm
	Weight:	1097 gr	Weight:	1097 gr	Weight:	552 gr	Weight:	960 gr
MASTERPACK	Length:	314 mm	Length:	314 mm	Length:	-	Length:	177 mm
DIMENSIONS	Width:	194 mm	Width:	194 mm	Width:	-	Width:	177 mm
	Height:	464 mm	Height:	464 mm	Height:	-	Height:	477 mm
	Weight:	1242 gr	Weight:	1260 gr	Weight:	-	Weight:	1091 gr
EURO PALLET	Bill units/pallet:	56	Bill units/pallet:	56	Bill units/pallet:	128	Bill units/pallet:	90
	Bill units/layer:	14	Bill units/layer:	14	Bill units/layer:	16	Bill units/layer:	9
	Layers/pallet:	4	Layers/pallet:	4	Layers/pallet:	8	Layers/pallet:	10
CONTAINER PALLET	Bill units/pallet:	100	Bill units/pallet:	100	Bill units/pallet:	224	Bill units/pallet:	182
HIGH CUBE	Bill units/layer:	20	Bill units/layer:	20	Bill units/layer:	28	Bill units/layer:	14
	Layers/pallet:	5	Layers/pallet:	5	Layers/pallet:	8	Layers/pallet:	13
EAN								
BILL UNIT	9 006206 312795		9 006206 313198		9 006206 312979		9 006206 312139	

DECANTERS



Limited Editions: TG reserves the right to offer glassware marked as "Limited Edition" in a certain amount and for a certain time period and under certain allocation criteria to Customer.



Cornetto Magnum Decanter



RIEDEL Cornetto Confetti Decanter
Yellow



RIEDEL Cornetto Confetti Decanter
Red



RIEDEL Cornetto Confetti Decanter
Blue

ITEM	Item no.:	1977/26	Item no.:	1977/13Y	Item no.:	1977/13R	Item no.:	1977/13B
	fine crystal handmade		fine crystal handmade		fine crystal handmade		fine crystal handmade	
	Height:	425 mm	Height:	325 mm	Height:	325 mm	Height:	325 mm
	Capacity:	1500 ccm	Capacity:	750 ccm	Capacity:	750 ccm	Capacity:	750 ccm
	Design:	2003	Design:	2020	Design:	2020	Design:	2020
PACKAGING	Pieces/Bill unit:	1	Pieces/Bill unit:	1	Pieces/Bill unit:	1	Pieces/Bill unit:	1
TYPE AND QUANTITY	Bill units/MP:	1	Bill units/MP:	1	Bill units/MP:	1	Bill units/MP:	1
BILL UNIT DIMENSIONS	Length:	172 mm	Length:	172 mm	Length:	172 mm	Length:	172 mm
	Width:	172 mm	Width:	172 mm	Width:	172 mm	Width:	172 mm
	Height:	476 mm	Height:	476 mm	Height:	476 mm	Height:	476 mm
	Weight:	960 gr	Weight:	660 gr	Weight:	660 gr	Weight:	660 gr
MASTERPACK DIMENSIONS	Length:	177 mm	Length:	177 mm	Length:	177 mm	Length:	177 mm
	Width:	177 mm	Width:	177 mm	Width:	177 mm	Width:	177 mm
	Height:	477 mm	Height:	477 mm	Height:	477 mm	Height:	477 mm
	Weight:	711 gr	Weight:	791 gr	Weight:	897 gr	Weight:	897 gr
EURO PALLET	Bill units/pallet:	90	Bill units/pallet:	90	Bill units/pallet:	90	Bill units/pallet:	90
	Bill units/layer:	9	Bill units/layer:	9	Bill units/layer:	9	Bill units/layer:	9
	Layers/pallet:	10	Layers/pallet:	10	Layers/pallet:	10	Layers/pallet:	10
CONTAINER PALLET HIGH CUBE	Bill units/pallet:	182	Bill units/pallet:	182	Bill units/pallet:	182	Bill units/pallet:	182
	Bill units/layer:	14	Bill units/layer:	14	Bill units/layer:	14	Bill units/layer:	14
	Layers/pallet:	13	Layers/pallet:	13	Layers/pallet:	13	Layers/pallet:	13
EAN BILL UNIT	 9 006206 311286		 9 006206 313716		 9 006206 313693		 9 006206 313709	

Kindly avoid overpouring the decanter. It's designed for specific fillings: 0.75L for regular, 1.5L for magnum, and 3L for double magnum.
Do keep in mind that sizes may vary due to the unique handmade nature of these decanters but they always hold the specified filling quantity.



DECANTERS



RIEDEL Cornetto Confetti Decanter
Green

RIEDEL Cornetto Confetti Decanter
Pink

ITEM	Item no.:	1977/13G	Item no.:	1977/13DP
	fine crystal handmade		fine crystal handmade	
	Height:	325 mm	Height:	325 mm
	Capacity:	750 ccm	Capacity:	750 ccm
	Design:	2020	Design:	2022
PACKAGING	Pieces/Bill unit:	1	Pieces/Bill unit:	1
TYPE AND QUANTITY	Bill units/MP:	1	Bill units/MP:	1
BILL UNIT DIMENSIONS	Length:	172 mm	Length:	172 mm
	Width:	172 mm	Width:	172 mm
	Height:	476 mm	Height:	476 mm
	Weight:	660 gr	Weight:	660 gr
MASTERPACK DIMENSIONS	Length:	177 mm	Length:	177 mm
	Width:	177 mm	Width:	177 mm
	Height:	477 mm	Height:	477 mm
	Weight:	897 gr	Weight:	897 gr
EURO PALLET	Bill units/pallet:	90	Bill units/pallet:	90
	Bill units/layer:	9	Bill units/layer:	9
	Layers/pallet:	10	Layers/pallet:	10
CONTAINER PALLET HIGH CUBE	Bill units/pallet:	182	Bill units/pallet:	182
	Bill units/layer:	14	Bill units/layer:	14
	Layers/pallet:	13	Layers/pallet:	13
EAN BILL UNIT				





Escargot Decanter



Curly Decanter



Curly Decanter
Pink

ITEM	Item no.: fine crystal handmade	2011/02	Item no.: fine crystal handmade	2011/04S1	Item no.: fine crystal handmade	2011/04
	Height:	150 mm	Height:	265 mm	Height:	265 mm
	Capacity:	750 ccm	Capacity:	750 ccm	Capacity:	750 ccm
	Design:	2011	Design:	2013	Design:	2013
PACKAGING	Pieces/Bill unit:	1	Pieces/Bill unit:	1	Pieces/Bill unit:	1
TYPE AND QUANTITY	Bill units/MP:	1	Bill units/MP:	1	Bill units/MP:	1
BILL UNIT	Length:	303 mm	Length:	303 mm	Length:	303 mm
DIMENSIONS	Width:	183 mm	Width:	183 mm	Width:	183 mm
	Height:	458 mm	Height:	458 mm	Height:	458 mm
	Weight:	1217 gr	Weight:	1047 gr	Weight:	1047 gr
MASTERPACK	Length:	314 mm	Length:	314 mm	Length:	314 mm
DIMENSIONS	Width:	194 mm	Width:	194 mm	Width:	194 mm
	Height:	464 mm	Height:	464 mm	Height:	464 mm
	Weight:	1393 gr	Weight:	1223 gr	Weight:	1223 gr
EURO PALLET	Bill units/pallet:	56	Bill units/pallet:	56	Bill units/pallet:	56
	Bill units/layer:	14	Bill units/layer:	14	Bill units/layer:	14
	Layers/pallet:	4	Layers/pallet:	4	Layers/pallet:	4
CONTAINER PALLET	Bill units/pallet:	100	Bill units/pallet:	100	Bill units/pallet:	100
HIGH CUBE	Bill units/layer:	20	Bill units/layer:	20	Bill units/layer:	20
	Layers/pallet:	5	Layers/pallet:	5	Layers/pallet:	5
EAN	 9 006206 311491		 9 006206 213344		 9 006206 213184	
BILL UNIT						

DECANTERS



Curly Fatto A Mano Decanter







Decanter ,O"
Magnum



Cornetto Single Decanter



Cornetto Fatto A Mano Decanter

ITEM	Item no.:	2011/00	Item no.:	1414/26	Item no.:	1977/13	Item no.:	1977/00
	fine crystal handmade		fine crystal handmade		fine crystal handmade		fine crystal handmade	
	Height:	265 mm	Height:	385 mm	Height:	325 mm	Height:	325 mm
	Capacity:	750 ccm	Capacity:	1500 ccm	Capacity:	750 ccm	Capacity:	750 ccm
	Design:	2018	Design:	2005	Design:	2003	Design:	2017
PACKAGING	Pieces/Bill unit:	1	Pieces/Bill unit:	1	Pieces/Bill unit:	1	Pieces/Bill unit:	1
TYPE AND QUANTITY	Bill units/MP:	1	Bill units/MP:	1	Bill units/MP:	1	Bill units/MP:	1
BILL UNIT DIMENSIONS	Length:	303 mm	Length:	172 mm	Length:	172 mm	Length:	172 mm
	Width:	183 mm	Width:	172 mm	Width:	172 mm	Width:	172 mm
	Height:	458 mm	Height:	476 mm	Height:	476 mm	Height:	476 mm
	Weight:	1047 gr	Weight:	1050 gr	Weight:	660 gr	Weight:	660 gr
MASTERPACK DIMENSIONS	Length:	314 mm	Length:	177 mm	Length:	177 mm	Length:	177 mm
	Width:	194 mm	Width:	177 mm	Width:	177 mm	Width:	177 mm
	Height:	464 mm	Height:	477 mm	Height:	477 mm	Height:	477 mm
	Weight:	1223 gr	Weight:	1181 gr	Weight:	861 gr	Weight:	870 gr
EURO PALLET	Bill units/pallet:	56	Bill units/pallet:	90	Bill units/pallet:	90	Bill units/pallet:	90
	Bill units/layer:	14	Bill units/layer:	9	Bill units/layer:	9	Bill units/layer:	9
	Layers/pallet:	4	Layers/pallet:	10	Layers/pallet:	10	Layers/pallet:	10
CONTAINER PALLET HIGH CUBE	Bill units/pallet:	100	Bill units/pallet:	182	Bill units/pallet:	182	Bill units/pallet:	182
	Bill units/layer:	20	Bill units/layer:	14	Bill units/layer:	14	Bill units/layer:	14
	Layers/pallet:	5	Layers/pallet:	13	Layers/pallet:	13	Layers/pallet:	13
EAN BILL UNIT	 9 006206 312924		 9 006206 311316		 9 006206 311279		 9 006206 312801	

Kindly avoid overpouring the decanter. It's designed for specific fillings: 0.75L for regular, 1.5L for magnum, and 3L for double magnum.
Do keep in mind that sizes may vary due to the unique handmade nature of these decanters but they always hold the specified filling quantity.



RIEDEL Decanter



RIEDEL Sakura Decanter



RIEDEL Chinese Zodiac Dragon Decanter
Red/Yellow



RIEDEL Chinese Zodiac Snake Decanter
Red/Yellow

ITEM	Item no.: fine crystal handmade	2015/02	Item no.: fine crystal handmade	2021/55	Item no.: fine crystal handmade	2009/2451	Item no.: fine crystal machine-made	2009/2551
	Height:	365 mm	Height:	365 mm	Height:	365 mm	Height:	365 mm
	Capacity:	750 ccm	Capacity:	750 ccm	Capacity:	750 ccm	Capacity:	750 ccm
	Design:	2015	Design:	2021	Design:	2024	Design:	2024
PACKAGING	Pieces/Bill unit:	1	Pieces/Bill unit:	1	Pieces/Bill unit:	1	Pieces/Bill unit:	1
TYPE AND QUANTITY	Bill units/MP:	1	Bill units/MP:	1	Bill units/MP:	1	Bill units/MP:	1
BILL UNIT	Length:	172 mm	Length:	172 mm	Length:	172 mm	Length:	172 mm
DIMENSIONS	Width:	172 mm	Width:	172 mm	Width:	172 mm	Width:	172 mm
	Height:	476 mm	Height:	476 mm	Height:	476 mm	Height:	476 mm
	Weight:	990 gr	Weight:	990 gr	Weight:	990 gr	Weight:	990 gr
MASTERPACK	Length:	177 mm	Length:	177 mm	Length:	177 mm	Length:	177 mm
DIMENSIONS	Width:	177 mm	Width:	177 mm	Width:	177 mm	Width:	177 mm
	Height:	477 mm	Height:	477 mm	Height:	477 mm	Height:	477 mm
	Weight:	1121 gr	Weight:	1121 gr	Weight:	1121 gr	Weight:	1121 gr
EURO PALLET	Bill units/pallet:	90	Bill units/pallet:	90	Bill units/pallet:	90	Bill units/pallet:	90
	Bill units/layer:	9	Bill units/layer:	9	Bill units/layer:	9	Bill units/layer:	9
	Layers/pallet:	10	Layers/pallet:	10	Layers/pallet:	10	Layers/pallet:	10
CONTAINER PALLET	Bill units/pallet:	182	Bill units/pallet:	182	Bill units/pallet:	182	Bill units/pallet:	182
HIGH CUBE	Bill units/layer:	14	Bill units/layer:	14	Bill units/layer:	14	Bill units/layer:	14
	Layers/pallet:	13	Layers/pallet:	13	Layers/pallet:	13	Layers/pallet:	13
EAN	 9 006206 312153		 9 006206 322008		 9 006206 325719		 9 006206 327232	
BILL UNIT								

DECANTERS



Limited Editions: TG reserves the right to offer glassware marked as "Limited Edition" in a certain amount and for a certain time period and under certain allocation criteria to Customer.



Black Tie Occhio Nero Decanter







Black Tie Smile Decanter



Black Tie Touch Decanter



Ultra Magnum Decanter

ITEM	Item no.: fine crystal handmade	2009/04	Item no.: fine crystal handmade	2009/01	Item no.: fine crystal handmade	2009/02	Item no.: fine crystal handmade	2400/13
	Height:	365 mm	Height:	365 mm	Height:	365 mm	Height:	240 mm
	Capacity:	750 ccm	Capacity:	750 ccm	Capacity:	750 ccm	Capacity:	1500 ccm
	Design:	2010	Design:	2010	Design:	2010	Design:	1994
PACKAGING	Pieces/Bill unit:	1	Pieces/Bill unit:	1	Pieces/Bill unit:	1	Pieces/Bill unit:	1
TYPE AND QUANTITY	Bill units/MP:	1	Bill units/MP:	1	Bill units/MP:	1	Bill units/MP:	1
BILL UNIT	Length:	172 mm	Length:	172 mm	Length:	172 mm	Length:	290 mm
DIMENSIONS	Width:	172 mm	Width:	172 mm	Width:	172 mm	Width:	290 mm
	Height:	476 mm	Height:	476 mm	Height:	476 mm	Height:	308 mm
	Weight:	990 gr	Weight:	1000 gr	Weight:	990 gr	Weight:	1301 gr
MASTERPACK	Length:	177 mm	Length:	177 mm	Length:	177 mm	Length:	299 mm
DIMENSIONS	Width:	177 mm	Width:	177 mm	Width:	177 mm	Width:	299 mm
	Height:	477 mm	Height:	477 mm	Height:	477 mm	Height:	314 mm
	Weight:	1121 gr	Weight:	1131 gr	Weight:	1121 gr	Weight:	1377 gr
EURO PALLET	Bill units/pallet:	90	Bill units/pallet:	90	Bill units/pallet:	90	Bill units/pallet:	48
	Bill units/layer:	9	Bill units/layer:	9	Bill units/layer:	9	Bill units/layer:	8
	Layers/pallet:	10	Layers/pallet:	10	Layers/pallet:	10	Layers/pallet:	6
CONTAINER PALLET	Bill units/pallet:	182	Bill units/pallet:	182	Bill units/pallet:	182	Bill units/pallet:	84
HIGH CUBE	Bill units/layer:	14	Bill units/layer:	14	Bill units/layer:	14	Bill units/layer:	12
	Layers/pallet:	13	Layers/pallet:	13	Layers/pallet:	13	Layers/pallet:	7
EAN	 9 006206 213085		 9 006206 212934		 9 006206 212941		 9 006206 310036	
BILL UNIT								

Kindly avoid overpouring the decanter. It's designed for specific fillings: 0.75L for regular, 1.5L for magnum, and 3L for double magnum. Do keep in mind that sizes may vary due to the unique handmade nature of these decanters but they always hold the specified filling quantity.



Black Tie Smile Decanter
Red



Black Tie Touch Decanter
Red



Black Tie Bliss Decanter
Red



Black Tie Bliss Decanter

ITEM	Item no.:	2009/01S3	Item no.:	2009/02S3	Item no.:	2009/03S3	Item no.:	2009/03
	fine crystal handmade		fine crystal handmade		fine crystal handmade		fine crystal handmade	
	Height:	365 mm	Height:	365 mm	Height:	365 mm	Height:	365 mm
	Capacity:	750 ccm	Capacity:	750 ccm	Capacity:	750 ccm	Capacity:	750 ccm
	Design:	2010	Design:	2010	Design:	2010	Design:	2010
PACKAGING	Pieces/Bill unit:	1	Pieces/Bill unit:	1	Pieces/Bill unit:	1	Pieces/Bill unit:	1
TYPE AND QUANTITY	Bill units/MP:	1	Bill units/MP:	1	Bill units/MP:	1	Bill units/MP:	1
BILL UNIT DIMENSIONS	Length:	172 mm	Length:	172 mm	Length:	172 mm	Length:	172 mm
	Width:	172 mm	Width:	172 mm	Width:	172 mm	Width:	172 mm
	Height:	476 mm	Height:	476 mm	Height:	476 mm	Height:	476 mm
	Weight:	1000 gr	Weight:	990 gr	Weight:	990 gr	Weight:	990 gr
MASTERPACK DIMENSIONS	Length:	177 mm	Length:	177 mm	Length:	177 mm	Length:	177 mm
	Width:	177 mm	Width:	177 mm	Width:	177 mm	Width:	177 mm
	Height:	477 mm	Height:	477 mm	Height:	477 mm	Height:	477 mm
	Weight:	1131 gr	Weight:	1121 gr	Weight:	1121 gr	Weight:	1121 gr
EURO PALLET	Bill units/pallet:	90	Bill units/pallet:	90	Bill units/pallet:	90	Bill units/pallet:	90
	Bill units/layer:	9	Bill units/layer:	9	Bill units/layer:	9	Bill units/layer:	9
	Layers/pallet:	10	Layers/pallet:	10	Layers/pallet:	10	Layers/pallet:	10
CONTAINER PALLET HIGH CUBE	Bill units/pallet:	182	Bill units/pallet:	182	Bill units/pallet:	182	Bill units/pallet:	182
	Bill units/layer:	14	Bill units/layer:	14	Bill units/layer:	14	Bill units/layer:	14
	Layers/pallet:	13	Layers/pallet:	13	Layers/pallet:	13	Layers/pallet:	13
EAN BILL UNIT	 9 006206 212989		 9 006206 213016		 9 006206 213047		 9 006206 212958	



Ultra Decanter







RIEDEL „O“ Single Decanter



Mosel Decanter



Medoc Decanter

ITEM	Item no.:	2400/14	Item no.:	1414/13	Item no.:	2019/03	Item no.:	2019/04
	fine crystal handmade		fine crystal handmade		fine crystal handmade		fine crystal handmade	
	Height:	225 mm	Height:	225 mm	Height:	290 mm	Height:	290 mm
	Capacity:	750 ccm	Capacity:	750 ccm	Capacity:	750 ccm	Capacity:	750 ccm
	Design:	1994	Design:	2006	Design:	2019	Design:	2019
PACKAGING TYPE AND QUANTITY	Pieces/Bill unit:	1	Pieces/Bill unit:	1	Pieces/Bill unit:	1	Pieces/Bill unit:	1
	Bill units/MP:	1	Bill units/MP:	1	Bill units/MP:	1	Bill units/MP:	1
BILL UNIT DIMENSIONS	Length:	290 mm	Length:	290 mm	Length:	172 mm	Length:	172 mm
	Width:	290 mm	Width:	130 mm	Width:	172 mm	Width:	172 mm
	Height:	308 mm	Height:	130 mm	Height:	476 mm	Height:	476 mm
	Weight:	1101 gr	Weight:	657 gr	Weight:	842 gr	Weight:	845 gr
MASTERPACK DIMENSIONS	Length:	299 mm	Length:	-	Length:	177 mm	Length:	177 mm
	Width:	299 mm	Width:	-	Width:	177 mm	Width:	177 mm
	Height:	314 mm	Height:	-	Height:	477 mm	Height:	477 mm
	Weight:	1240 gr	Weight:	-	Weight:	973 gr	Weight:	976 gr
EURO PALLET	Bill units/pallet:	48	Bill units/pallet:	280	Bill units/pallet:	90	Bill units/pallet:	90
	Bill units/layer:	8	Bill units/layer:	20	Bill units/layer:	9	Bill units/layer:	9
	Layers/pallet:	6	Layers/pallet:	14	Layers/pallet:	10	Layers/pallet:	10
CONTAINER PALLET HIGH CUBE	Bill units/pallet:	84	Bill units/pallet:	527	Bill units/pallet:	182	Bill units/pallet:	182
	Bill units/layer:	12	Bill units/layer:	31	Bill units/layer:	14	Bill units/layer:	14
	Layers/pallet:	7	Layers/pallet:	17	Layers/pallet:	13	Layers/pallet:	13
EAN BILL UNIT	 9 006206 310920		 9 006206 311293		 9 006206 313266		 9 006206 313273	

Kindly avoid overpouring the decanter. It's designed for specific fillings: 0.75L for regular, 1.5L for magnum, and 3L for double magnum.
Do keep in mind that sizes may vary due to the unique handmade nature of these decanters but they always hold the specified filling quantity.





Macon Decanter



Marne Decanter



Margaux Decanter

ITEM	Item no.: fine crystal handmade	2017/01	Item no.: fine crystal handmade	2017/02	Item no.: fine crystal handmade	2017/03
	Height:	210 mm	Height:	200 mm	Height:	153 mm
	Capacity:	750 ccm	Capacity:	750 ccm	Capacity:	750 ccm
	Design:	2017	Design:	2017	Design:	2017
PACKAGING	Pieces/Bill unit:	1	Pieces/Bill unit:	1	Pieces/Bill unit:	1
TYPE AND QUANTITY	Bill units/MP:	1	Bill units/MP:	1	Bill units/MP:	1
BILL UNIT	Length:	260 mm	Length:	260 mm	Length:	260 mm
DIMENSIONS	Width:	260 mm	Width:	260 mm	Width:	260 mm
	Height:	240 mm	Height:	240 mm	Height:	240 mm
	Weight:	668 gr	Weight:	668 gr	Weight:	668 gr
MASTERPACK	Length:	266 mm	Length:	266 mm	Length:	266 mm
DIMENSIONS	Width:	266 mm	Width:	266 mm	Width:	266 mm
	Height:	244 mm	Height:	244 mm	Height:	244 mm
	Weight:	883 gr	Weight:	883 gr	Weight:	883 gr
EURO PALLET	Bill units/pallet:	84	Bill units/pallet:	84	Bill units/pallet:	84
	Bill units/layer:	12	Bill units/layer:	12	Bill units/layer:	12
	Layers/pallet:	7	Layers/pallet:	7	Layers/pallet:	7
CONTAINER PALLET	Bill units/pallet:	144	Bill units/pallet:	144	Bill units/pallet:	144
HIGH CUBE	Bill units/layer:	16	Bill units/layer:	16	Bill units/layer:	16
	Layers/pallet:	9	Layers/pallet:	9	Layers/pallet:	9
EAN		9 006206 312733		9 006206 312740		9 006206 312757
BILL UNIT						



DECANTERS MACHINE-MADE
NO R.Q. AVAILABLE



RIEDEL Veloce Decanter Restaurant







Mosel Decanter machine-made



Syrah Decanter



RIEDEL Apple NY Decanter



ITEM	Item no.: fine crystal machine-made	1336/13	Item no.: fine crystal machine-made	1416/03	Item no.: fine crystal machine-made	1486/13	Item no.: fine crystal machine-made	1466/13
	Height/glass:	255 mm	Height/glass:	285 mm	Height/glass:	245 mm	Height/glass:	195 mm
	Capacity/glass:	1300 ccm	Capacity/glass:	1320 ccm	Capacity/glass:	1040 ccm	Capacity/glass:	1420 ccm
	Design:	2024	Design:	2022	Design:	2017	Design:	2014
PACKAGING	Pieces/Bill unit:	1	Pieces/Bill unit:	1	Pieces/Bill unit:	1	Pieces/Bill unit:	1
TYPE AND QUANTITY	Bill units/MP:	6	Bill units/MP:	6	Bill units/MP:	6	Bill units/MP:	6
BILL UNIT	Length:	384 mm	Length:	340 mm	Length:	446 mm	Length:	417 mm
DIMENSIONS	Width:	258 mm	Width:	230 mm	Width:	297 mm	Width:	282 mm
	Height:	267 mm	Height:	295 mm	Height:	264 mm	Height:	202 mm
	Weight:	2410 gr	Weight:	2485 gr	Weight:	2206 gr	Weight:	2102 gr
EURO PALLET	Bill units/pallet:	378	Bill units/pallet:	360	Bill units/pallet:	252	Bill units/pallet:	324
	Bill units/layer:	54	Bill units/layer:	60	Bill units/layer:	36	Bill units/layer:	36
	Layers/pallet:	7	Layers/pallet:	6	Layers/pallet:	7	Layers/pallet:	9
CONTAINER PALLET	Bill units/pallet:	576	Bill units/pallet:	630	Bill units/pallet:	432	Bill units/pallet:	594
HIGH CUBE	Bill units/layer:	72	Bill units/layer:	90	Bill units/layer:	54	Bill units/layer:	54
	Layers/pallet:	8	Layers/pallet:	7	Layers/pallet:	8	Layers/pallet:	11
EAN								
BILL UNIT	9 006206 326983		9 006206 323265		9 006206 525898		9 006206 311828	



Performance Decanter



Merlot Decanter

ITEM	Item no.: 1496/13 fine crystal machine-made Height/glass: 245 mm Capacity/glass: 1364 ccm Design: 2018	Item no.: 1446/14 fine crystal machine-made Height/glass: 240 mm Capacity/glass: 970 ccm Design: 2004
PACKAGING TYPE AND QUANTITY	Pieces/Bill unit: 1 Bill units/MP: 6	Pieces/Bill unit: 1 Bill units/MP: 6
BILL UNIT DIMENSIONS	Length: 446 mm Width: 297 mm Height: 264 mm Weight: 2176 gr	Length: 359 mm Width: 245 mm Height: 253 mm Weight: 1882 gr
EURO PALLET	Bill units/pallet: 252 Bill units/layer: 36 Layers/pallet: 7	Bill units/pallet: 378 Bill units/layer: 54 Layers/pallet: 7
CONTAINER PALLET HIGH CUBE	Bill units/pallet: 432 Bill units/layer: 54 Layers/pallet: 8	Bill units/pallet: 702 Bill units/layer: 78 Layers/pallet: 9
EAN BILL UNIT	 9 006206 528233	 9 006206 513130



RIEDEL Microfiber Polishing Cloths



RIEDEL Microfiber Polishing Cloth

ITEM	Item no.: 5010/07	Item no.: 0010/07
	-	-
	-	-
	Height/glass: -	Height/glass: -
	Capacity/glass: -	Capacity/glass: -
	Design: 2010	Design: 2006
PACKAGING	Pieces/Bill unit: 20	Pieces/Bill unit: 1
TYPE AND QUANTITY	Bill units/MP: 1	Bill units/MP: -
BILL UNIT	Length: 285 mm	Length: -
DIMENSIONS	Width: 186 mm	Width: -
	Height: 6 mm	Height: -
	Weight: 2206 gr	Weight: 85 gr
EURO PALLET	Bill units/pallet: 2600	Bill units/pallet: 4320
	Bill units/layer: 260	Bill units/layer: 720
	Layers/pallet: 10	Layers/pallet: 6
CONTAINER PALLET	Bill units/pallet: 4400	Bill units/pallet: 9600
HIGH CUBE	Bill units/layer: 440	Bill units/layer: 1200
	Layers/pallet: 10	Layers/pallet: 8
EAN		
BILL UNIT	9 006206 212798	9 006206 212781



1. ADDITIONAL COSTS FOR CUSTOMERS CALIBRATION AND POUR AID

- No stock production. Manufacturing after fix order.
- per glass size (for re-orders as well).
- A quantity +/- 10% compared to the order quantity has to be accepted by the client.

The following prices are given for special calibrations and pour aid as per the German Calibration Act, if they are not included in the collection according to the price list:

prices per piece and per glass size orders exceeding: (Single marks / Double marks)	120 pcs.	600 pcs.	2500 pcs.
machine blown glass	£ 1.70	£ 1.40	on request

Tolerances must be taken into account for calibration markings and pour lines.

Nominal volume	Tolerance
10 – 99 ml	+/- 15%
100 – 199 ml	+/- 10%
=/>200 ml	+/- 5%

2. SIGNETS & VIGNETTES - SILK SCREEN PRINTING (WITHOUT CALIBRATION AND POUR AID)

- On bowl only.
- No stock production. Manufacturing after fix order.
- Minimum order quantity 60 pieces per glass size (for re-orders as well).
- A quantity +/- 10% compared to the order quantity has to be accepted by the client.

For the first production you have to pay non-recurring tool costs of £350.00 if you have a appropriate artwork. If we have to re-produce the artwork we have to charge approx £500.00. May we ask you to send us your artwork in order or us to determine the appropriate technique to execute your vignette. Silk screen printing costs for Gold and Platinum upon request.

pieces	prices per piece and per glass size orders exceeding: for stem glasses machine-made; color: matt white
60 pcs.	£ 8.40
120 pcs.	£ 5.60
240 pcs.	£ 3.40
300 pcs.	£ 2.95
420 pcs.	£ 2.65
540 pcs.	£ 2.05
1.200 pcs.	£ 1.35
2.500 pcs.	£ 1.20
5.000 pcs.	£ 0.90
10.000 pcs.	£ 0.75



3. SIGNETS & VIGNETTES - SILK SCREEN PRINTING (INCLUDING CALIBRATION AND POUR AID)

- No stock production. Manufacturing after fix order.
- Minimum order quantity 120 pieces per glass size (for re-orders as well).
- A quantity +/- 10% compared to the order quantity has to be accepted by the client.

prices per piece and per glass size orders exceeding:	120 pcs.	240 pcs.	600 pcs.	2500 pcs.
For stem glasses, machine made Color: malt white	£ 5.95	£ 3.65	£ 2.25	on request

For the first production you have to pay a one time tool costs of £350.00 you have the appropriate artwork. If we have to re-produce the artwork we have to charge approx £500.00. May we ask you to send us your artwork in order to determine the appropriate technique to execute your vignette. Silk screen printing costs for Gold and Platinum upon request.

4. INFORMATION ABOUT SILK SCREEN DECORATION:

In decorating glass with the screen printing process, colour is pressed through a silk screen to the glass surface and fixed to the glass during a temperature treatment. The colours, used by RIEDEL, are organic colours without heavy metals (such as lead, barium, etc.) or other toxic components. These colours have a high dishwasher resistance, but compared with ceramic colours a lower mechanical resistance.

5. ATTENTION:

The water hardness for cleaning glass, should not be less than 3° d.H.

Glasses with organic colours should be placed in the dishwasher in a way that they cannot make contact with each other during the washing process. If cleaning the glasses by hand, please do not use a scouring brush or abrasive detergents.

Be aware that fully desalinated water is extremely aggressive to both the glass surface and screen print decoration.

Over/underproduction (+10/-10 %) may be possible and will be billed accordingly.

pieces	fine laser for superlight glasses (RIEDEL Superleggero, RIEDEL Veloce)
100 pcs.	£ 12.25
120 pcs.	£ 11.20
360 pcs.	£ 6.65
600 pcs.	£ 4.20
1000 pcs.	£ 3.50



SEPARATE
PROCESS

MICROFIBER POLISHING CLOTH

- Wash with odorless soap
- Should be machine washed at 140° F/60° C
- Never use fabric softener when rinsing your microfiber polishing cloth (avoids grease film on surface)



CARING FOR YOUR RIEDEL CRYSTAL

- MOST RIEDEL GLASSES ARE DISHWASHER SAFE!
- RIEDEL exclusively recommends Miele dishwashers.
- To avoid scratches: Avoid glass contact with other glass or metal. If available use a stemware rack.
- To avoid stains: Use soft water (low mineral content).
- To remove stains: Use white vinegar.

IF WASHING BY HAND

- Wash the glass under warm water (use detergent and rinse the glass carefully)
- Glass polishing: Use two polishing cloths, never hold the glass by the base to polish the bowl
- Stem snap: Occurs through mishandling = torque or bend pressure at the stem
- Storage: Avoid glass storage in kitchen cabinets which have strong aromas that translates into glass



FOR INFORMATION ON GLASS CARE AND HOW TO WASH GLASSWARE, VISIT RIEDEL.COM.

For a perfect result

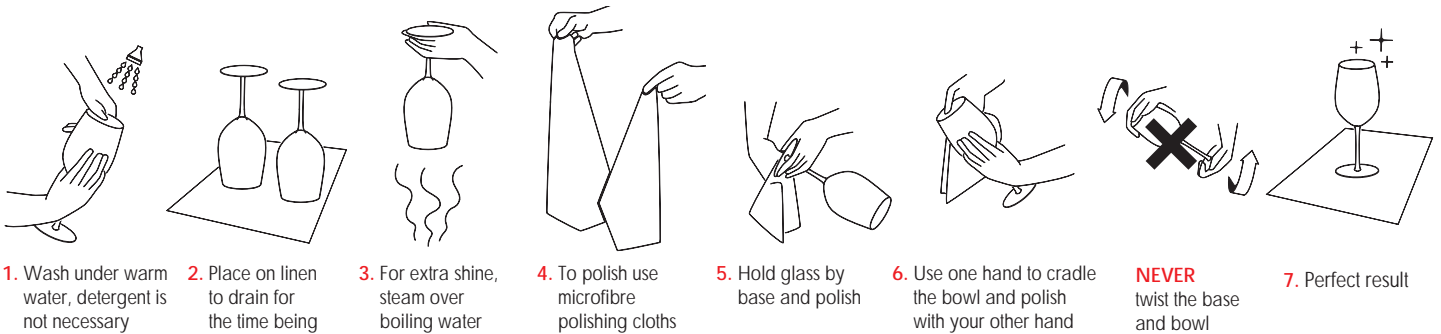

1. Wash under warm water, detergent is not necessary
2. Place on linen to drain for the time being
3. For extra shine, steam over boiling water
4. To polish use microfibre polishing cloths
5. Hold glass by base and polish
6. Use one hand to cradle the bowl and polish with your other hand
- NEVER** twist the base and bowl
7. Perfect result



CAUTION: A RIEDEL glass is a grape varietal specific wine tool! This shape works best with wines made from specific grapes. Please read the instructions below to guarantee maximum enjoyment. RIEDEL has researched the

grape varietal sensation, leading to the conclusion, on which the world's wine experts agree; that the enjoyment of aroma, taste, texture and finish of a wine, is maximized by using the right "WINE TOOL"

Rules when handling connoisseur glasses



1 Filling the glass

Do not over-pour. This will ensure maximum development of the wine's bouquet, and also provide the most elegant table setting.



2 Holding the glass

The appropriately filled glass should always be held by the stem rather than the bowl.



3 Swirling the glass

Carefully swirling the glass allows oxygen into the wine by increasing its surface area and helps release the wine's rich, mature aroma.



4 Why and how to decant wines

To decant wine means to transfer it from its bottle to a decanter or carafe before drinking. During storage or aging, wine can develop a solid deposit or sediment at the bottom of the bottle. Decanting is an easy means of separating the sediment from the wine. It also helps the wine breathe, as the greater surface diameter lets more oxygen reach the wine than the bottle does.



5 Wine temperature

Before decanting/or serving wine, store it at appropriate temperatures (red wine 59–63°F, 15–17°C, white wines at 50–54°F, 10–12°C). The proper serving temperature enhances the quality of the wine by allowing it to fully develop its characteristic aromas and flavours.

(1) *Riedel*(2) **RIEDEL**

The RIEDEL TRADEMARK dates from the Art Nouveau period at the end of the nineteenth century, and was used for RIEDEL glassware made in Bohemia from 1890 to 1925. In 1996, to commemorate RIEDEL'S 240th anniversary, we reintroduced this trademark for all our handmade and hand-finished products. The distinctive Riedel signature is now featured on the base of all these products. This signature trademark (1) helps our customers to distinguish immediately between handmade, hand-finished products and those made by machine (2). Our machine-made products carry this trademark. The RIEDEL glass dynasty is built on the creative energies of a long line of glassmakers. The story begins in 1756 in Bohemia and continues right down to the united Europe of today, taking in on the way some of the most dramatic events in European history.

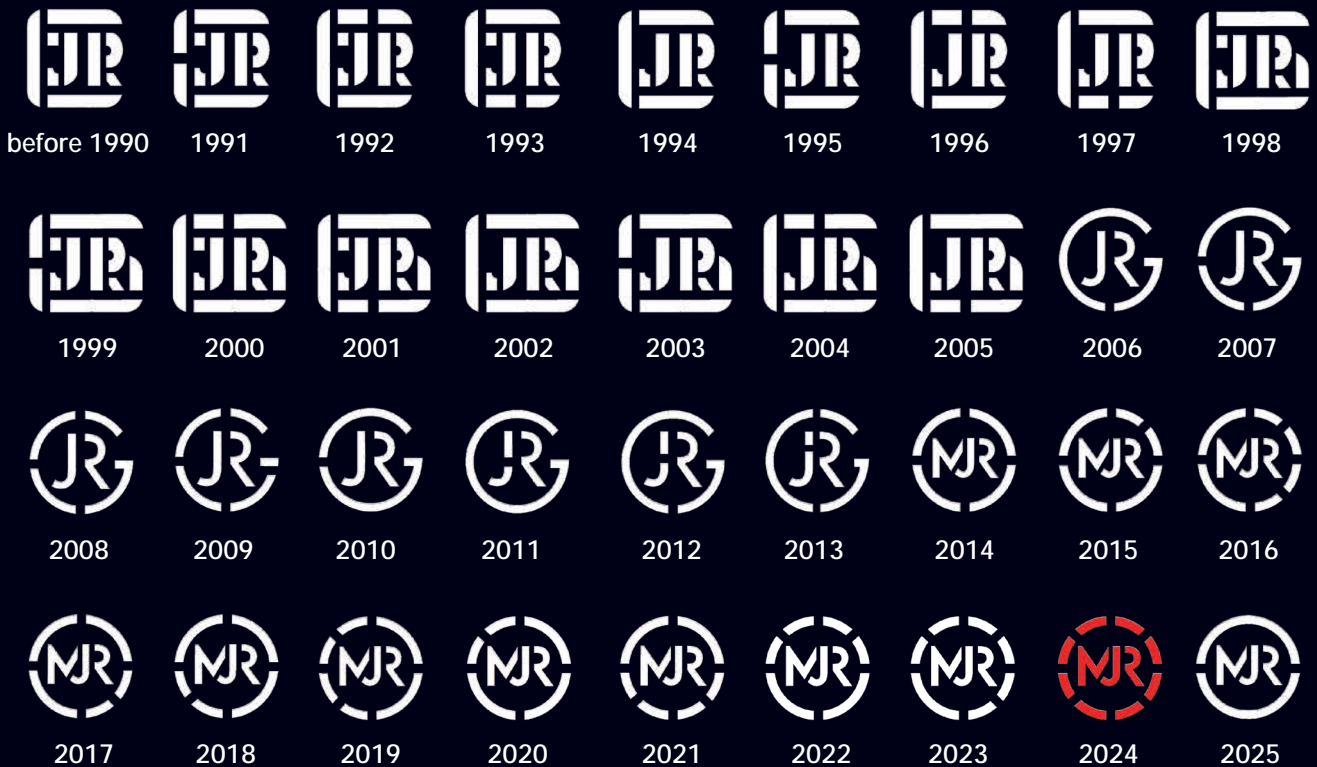

HANDMADE ITEMS

FOR COLOURED DECANTERS:

- minimum order of **25 decanters**
- all handmade decanters can be customized BUT limited edition colours can not be used, also metal colours like gold are not available
- No samples will be sent prior, note that colours cannot be predicted due to the fact, that this is depending on how thin the glass is blown.
- **50% Pre-payment** applies.
- For customized items, Riedel would ask that customers be amenable to accepting an **over or under production of 20%**.

Exception: Face to Face

- **minimum order 15 pieces WITHOUT** any upcharge.
- Process: please provide profile image, we will than do a drawing which has to be approved by the customer prior production.
- No samples will be available prior production.
- All customized items are excluded from promotions.

FOR DECANTER (SHAPES):

- existing shape, which is no longer in collecti (discontinued) can be reproduced
- a minimum order **of 50 decanters**
- prices on request

FOR CUSTOMIZED STEMWARE:

- Minimum order quantity: 175 pcs.
- 50% Pre-payment applies.



EVE
1950/09-S7

BLACK TIE
FACE TO FACE
4100/13

CUSTOMIZED 'OCCHIO NERO' DECANTER

Pre-Arrangements

- Before we can confirm your order, we require the logo from you. This will allow us to assess its technical feasibility.
- The line width must at least 2 mm at all parts of the logo.
- 50% Pre-payment applies.

Sampling

- Even if only one single sample is required we need a high quality stamp as per attached picture, therefore we have to charge £1,000.00 for the sample.
- Stamp lasts for approx: 250 prints
- re-order of existing stamp motive £500.00
- Sample has to be approved by the customer.

Basic parameters for orders

- Minimum order quantity: 50 pcs
- For customized items, Riedel would ask that customers be amenable to accepting an over or under production of 10%.



BLACK TIE
OCCHIO NERO
2009/04

Offer valid for alteration of logo etc. within the elliptical-shaped dent, variations of shape of dent have to be quoted separately.



Example for stamp

Embossing is possible in 3 basic shapes:

- 1 Circle of 60 mm
- 2 Small oval of 69 x 41 mm
- 3 Large oval of 76 x 50 mm

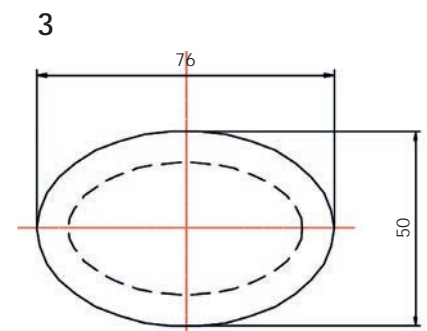
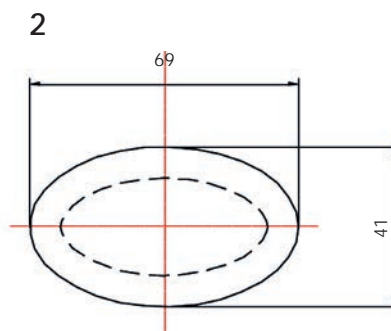
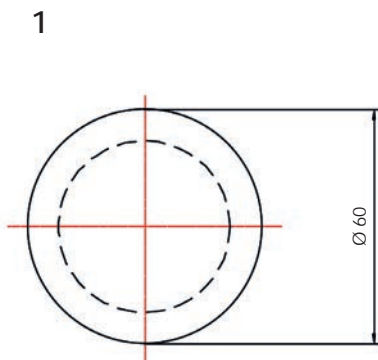

CUSTOMIZATION OF PRESSED TUMBLERS

YOUR LOGO ON YOUR TUMBLER

Design options only apply to the following tumblers:



0417/01
Neat Glass



0417/02
Rocks Glass



0417/04
Highball Glass



0417/03
Fizz Glass



0417/07
Double Rocks Glass



0418/01
RIEDEL Spey
Single Old Fashioned



0418/02
RIEDEL Spey
Whisky



0418/04
RIEDEL Spey
Longdrink



0512/02S1
RIEDEL Fire
Whisky



0512/04S1
RIEDEL Fire
Longdrink



0512/02S5
RIEDEL Shadows
Tumbler



0419/01
Single Old Fashioned



0419/02
Double Old Fashioned



0419/04
Highball



DESIGN EXAMPLE

TERMS & CONDITIONS:

- MOQ: 5,000 PIECES.
- Larger quantities upon request.
- Product will be packed in unbranded bulk packaging (brown boxes of 12 pcs.).
- Gift boxing must be calculated and quoted separately
- Offer cannot be combined with the original brand of the product but must have a hot stamp with a customer brand on it.
- Lead time is minimum 15 weeks (customized production needs to be combined with RIEDEL branded production run + molds need to be ordered).
- Terms of Delivery: Ex Works from our factories.
- No promotion discount can be applied.
- General Terms & Conditions apply.

MINIMUM ORDER QUANTITY & PRICES:

Order quantity	Frontline price + upcharge
5,000 pcs.	£ 3.50
7,500 pcs.	£ 3.15
10,000 pcs.	£ 2.80



GO GREEN - SUSTAINABILITY



Our Glassware

- Durable / sustainable product - long lasting and reusable for many years
- Up to 50% made from recycled Riedel crystal within our factories
- Crystal-Glass is inert and does not react with substances or materials that it comes into contact with (in contrast to plastic which, for example, can release Bisphenol A (BPA))
- Production processes are completely BPA-free / no plastic
- Our crystal glass is compliant with all known migration limits and is fully certified for safe usage with food and drinks
- 100% recyclable



Our Packaging

- Green Dot certified (production sites Germany - the company is committed to recovery and recycling)
- 45% FSC® - Forest Stewardship Council
- Reclay whole system (production sites Austria)
- Recyclable
- We work with sustainability-committed suppliers only. For example, with Mondi RIEDEL has won a Sustainability Award for the jointly developed packaging solution from Riedel Performance.



Our Factories

- Implemented environment certificates
ISO 14001: 2015 and ISO 50001: 2011
- Main raw materials are locally sourced e.g. quartz sand from Hirschau (short transport routes)
- Energy-saving projects include: compressed air, burner technology, energy efficient drives, LED lighting, waste heat recovery, water saving measures
- Substitution of hazardous substances with more environmentally friendly options

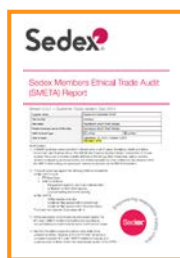

www.riedel.com

GENERAL TERMS AND CONDITIONS

TERMS AND CONDITIONS OF SALE OF RSN.UK LTD (MAY 2024)

1. Definitions and Interpretation.

1.1. In these terms and conditions of sale of RSN.UK Limited the following words and expressions shall have the following meanings:

„Conditions“ means the terms and conditions of sale set out in this document, subject to any variation agreed in accordance with Condition 2.3. „Contract“ means the contract between Riedel and the Customer for the sale and purchase of the Goods in accordance with the Contract Documents. „Contract Documents“ means in relation to each Contract:

- (a) these Conditions;
- (b) the Order Confirmation;
- (c) the Delivery Note; and
- (d) any other document, signed by a duly authorised representative of each of Riedel and the Customer, that expressly provides that it is a Contract Document for the purposes of the Contract, and „Contract Document“ shall mean any one of them.

„Contract Price“ means the total price for the Goods (including VAT and delivery charges (if applicable)) as set out in the relevant Order Confirmation.

„Customer“ means the corporation, partnership, sole trader, company or other entity, who has entered into the Contract with and purchases the Goods from Riedel. „Delivery Note“ means the note signed by the Customer when the Goods are delivered.

„Force Majeure“ means the occurrence of any circumstance or event beyond the reasonable control of Riedel or any of its suppliers. Without prejudice to the generality of the definition, an event of Force Majeure may include any of the following:

- (a) an event or threat of war, act of terrorism, civil disturbance or requisition; or
- (b) an act of God, flood, tempest, fire or accident; or
- (c) acts, restrictions, regulations, bye-laws, prohibitions or measures of any kind on the part of any agency, governmental, parliamentary or local authority; or
- (d) import or export regulations or embargoes; or
- (e) strikes, lock outs or other industrial actions or trade disputes (whether involving Riedel’s employees or employees of a third party); or
- (f) difficulties in obtaining raw materials, labour, fuel, parts or machinery or increases in the costs of the same; or
- (g) power failure or breakdown in machinery; or
- (h) foreign exchange fluctuations and currency regulation; or
- (i) any change in delivery dates, quantities or specifications for Goods requested by the Customer. „Goods“ means the goods or services (or any part of them) specified in the Order Confirmation.

„Intellectual Property“ means any and all copyrights, patents, design rights, trade marks (including without limitation the Trade Marks), database rights, names, signs, logos, symbols, photographs, videos and all other intellectual property rights, whether registered or unregistered, owned by Riedel or its licensors.

„Order“ means the Customer’s order for the Goods, as set out in the Customer’s purchase order form, the Customer’s written acceptance of Riedel’s quotation, or overleaf, as the case may be. „Order Confirmation“ means an order confirmation document issued by Riedel to the Customer agreeing to fulfil an Order.

„Riedel“ means RSN.UK Limited (company number 01418281) whose registered office is Lakeside House, 3 Trentham Office Village, Bellringer Road, Trentham Lakes South, Stoke on Trent, ST4 8GH, UK. „Special Orders“ means an Order for Goods not featured in Riedel’s standard price books including Goods produced to the Customer’s specification or altered in accordance with the Customer’s requirements. „Trade Marks“ means those marks and logos advised by Riedel to the Customer from time to time including the words „Riedel“, „Nachtmann“ and „Spiegelau“.

„Writing“ means facsimile transmission, electronic communication and comparable means of communication and „written“ shall be construed accordingly.

1.2. All references herein to Conditions are references to these Conditions unless otherwise specified.

2. General.

2.1. These Conditions apply to the Contract to the exclusion of any other terms and conditions stipulated or referred to by the Customer or which the Customer otherwise seeks to apply, or which are implied by trade, custom, practice or course of dealing.

2.2. Any terms and conditions (whether express or implied or imputed by custom or course of dealing) upon which the Customer and Riedel have previously entered into contracts shall not apply, unless expressly incorporated in the Order Confirmation.

2.3. These Conditions may only be varied or supplemented at the express written instigation, or with the express written permission, of Riedel.

2.4. The Order constitutes an offer by the Customer to purchase the Goods in accordance with these Conditions. A quotation for the Goods given by Riedel will not constitute an offer. A binding contract (incorporating these Conditions), under which Riedel will supply and the Customer will buy the Goods, will be formed on the issue by Riedel of the Order Confirmation.

2.5. Each Order shall be deemed to be a separate offer by the Customer to buy the Goods, which Riedel shall be free to accept or reject at any time without reason at its absolute discretion. No Order shall be deemed to be accepted by Riedel until it issues an Order Confirmation or (if earlier) Riedel delivers the Order to the Customer.

2.6. The acceptance of an Order or performance of deliveries by Riedel may not be regarded as the grant of any entitlement to future deliveries or to any exclusivity whatsoever.

2.7. Any Orders placed are binding on the Customer. However, the Customer may modify an Order within 5 (five) days of placing it by Written notice to Riedel provided that Riedel has not issued the Order Confirmation by this time.

2.8. The Goods are described in the specification provided to the Customer.

2.9. Without prejudice to Condition 2.5, Riedel reserves the right to (i) accept Orders only with respect to amounts that from Riedel’s experience correspond with usual quantities ordered by entities of comparable size to the Customer and/ or (ii) make any alterations, which it considers reasonable in the specification or materials used in the Goods whether before or after the making of the Contract in order to enable Riedel to pursue its policy of continuous improvement of its products. Any samples, drawings, descriptive matter or advertising produced by Riedel and any descriptions or illustrations contained in Riedel’s catalogues or brochures are produced for the sole purpose of giving an approximate idea of the Goods referred to in them. They shall not form part of the Contract nor have any contractual force.

2.10. Special Orders require a minimum deposit of 50% of the Contract Price payable in advance in accordance with Condition 7.2. Special Orders cannot be combined with any other Orders to meet order minimums, unless otherwise agreed in Writing by Riedel. Quantities of Special Orders can be ordered in full master packs only. No returns or cancellations on Special Orders are permitted.

2.11. Customized packaging is subject to a separate packaging agreement, which shall be separately negotiated and agreed between the parties.

2.12. Where the Goods involve any services to be provided by Riedel to the Customer:

- (a) such services shall be supplied in accordance with the relevant service specification;
- (b) Riedel shall use all reasonable endeavours to meet any performance dates specified in the Contract Documents, but any such dates shall be estimates only and time shall not be of the essence for the performance of any such services;
- (c) Riedel reserves the right to amend the relevant service specification to comply with any applicable law or regulatory requirement; and
- (d) Riedel warrants to the Customer that such services will be provided using reasonable care and skill.

3. Delivery.

3.1. Unless otherwise stated in the Order Confirmation, Riedel will be responsible for arranging the delivery of the Goods to the Customer to the location specified in the relevant Order or such other location as the parties may agree, title and risk in which shall pass to the Customer in accordance with Condition 4. below.

3.2. Dates or periods for delivery set out in any Contract Document are approximate and are given for information purposes only. Time for delivery is not of the essence and late delivery of any Goods shall not constitute a breach of Contract and shall not entitle the Customer to avoid the Contract or to any other remedy.

3.3. Riedel may deliver Orders by instalments, which may be invoiced and paid for separately. Any delay in delivery or defect in an instalment shall not entitle the Customer to cancel the overall Contract or any other instalment.

3.4. If the Customer fails to take or accept delivery of the Goods on the delivery date notified to the Customer by Riedel and/ or fails to provide any instructions, documents, licences, consents or authorisations required to enable the Goods to be delivered on that date, Riedel shall notify the Customer that it intends to store or arrange the storage of the Goods on its behalf, whereupon Riedel shall be deemed to have been authorised by the Customer so to do, and on the giving of such notice (i) risk in the Goods will pass to the Customer, (ii) delivery of the Goods will be deemed to have taken place, and (iii) the Customer will be deemed to have accepted the Goods as to quality, specification and condition. The Customer will promptly reimburse Riedel in respect of all costs and expenses including storage and insurance charges arising from such failure to take or accept delivery.

3.5. If 10 (ten) business days after Riedel has notified the Customer that the Goods were ready for delivery, the Customer has not taken delivery of them, Riedel may resell or otherwise dispose of part or all of the Goods.

3.6. All Goods are shipped in brown master packs. The master pack is to protect the Goods only and is not designed to be used as shippable outer carton. Any other use of this master pack, in particular, its use for shipping, is at the sole responsibility and at the risk of the Customer.

3.7. If Riedel delivers up to and including 5% more or less than the quantity of Goods ordered, the Customer may not reject them. The quantity actually delivered is to be paid for in full in all cases and, on receipt of notice from the Customer that the wrong quantity of Goods was delivered, a pro rata adjustment shall be made to the Order invoice.

4. Passing of Risk and Title.

4.1. Risk in the Goods shall pass to the Customer when:

- (a) in the case of Goods to be delivered at the Customer’s premises, the Goods are dispatched from Riedel’s premises;

- (b) in the case of Goods to be delivered at Riedel's premises, Riedel notifies the Customer that the Goods are available for collection; or
- (c) Riedel gives notice to the Customer as permitted in Condition 3.4.
- 4.2. Title to the Goods shall not pass to the Customer until the earlier of:
- (a) Riedel receiving payment in full (in cash or cleared funds) for the Goods and any other goods that Riedel has supplied to the Customer in respect of which payment has become due, in which case title to the Goods shall pass at the time of payment of all such sums; and
- (b) the Customer reselling the Goods, in which case title to the Goods shall pass to the Customer at the time specified in Condition 4.4.
- 4.3. Until title to the Goods has passed to the Customer, the Customer shall:
- (a) store the Goods separately from all other goods held by the Customer so that they remain readily identifiable as Riedel's property;
- (b) not remove, deface or obscure any identifying mark or packaging on or relating to the Goods;
- (c) maintain the Goods in satisfactory condition and keep them insured against all risks for their full price from the date of delivery;
- (d) notify Riedel immediately if it becomes subject to any of the events listed in Condition 5.1; and
- (e) give Riedel such information relating to the Goods as Riedel may require from time to time.
- 4.4. Subject to Condition 4.5., the Customer may resell or use the Goods in the ordinary course of its business (but not otherwise) before Riedel receives payment for the Goods. However, if the Customer resells the Goods before that time:
- (a) it does so as principal and not as Riedel's agent; and
- (b) title to the Goods shall pass from Riedel to the Customer immediately before the time at which resale by the Customer occurs.
- 4.5. If before title to the Goods passes to the Customer, the Customer becomes subject to any of the events listed in Condition 5.1., then, without limiting any other right or remedy Riedel may have:
- (a) the Customer's right to resell the Goods or use them in the ordinary course of its business ceases immediately; and
- (b) Riedel may at any time (i) require the Customer to deliver up all Goods in its possession that have not been resold, or irrevocably incorporated into another product and (ii) if the Customer fails to do so promptly, enter any premises of the Customer or of any third party where the Goods are stored in order to recover them.
5. Riedel's Termination Rights.
- 5.1. Without prejudice to its other rights and remedies, Riedel shall be entitled to demand immediate payment of all outstanding amounts and immediately terminate wholly or in part any or every Contract between itself and the Customer or suspend any further deliveries under any Contract on the occurrence of any of the following events:
- (a) any debt due and payable by the Customer to Riedel is unpaid, or the Customer fails to provide any letter of credit, bill of exchange or any other security required by the Contract Documents or the Customer is otherwise in breach of any of its obligations under the Contract Documents;
- (b) the Customer fails to take or accept delivery of any of the Goods under any contract between it and Riedel (other than in accordance with any rights the Customer has to refuse to take or accept delivery under the contract in question);
- (c) the Customer becomes insolvent or is unable to pay its debts within the meaning of Section 123 of the Insolvency Act 1986 or enters into any composition or arrangement (including a voluntary arrangement) with its creditors or, has passed a resolution for voluntary winding up except where solely for the purpose of reconstruction, or if a petition has been presented for an order for its winding up or for a receiver (which expression shall include an administrative receiver) or administrator to be appointed or if any such order or appointment is made or if, being an individual or partnership, the Customer suspends payment of his or their debts in whole or in part or if an application has been made for an interim order or a petition has been presented for a bankruptcy order or if any such order is made or if the Customer, whether or not a body corporate, shall carry out or be subject to any analogous act or proceedings under any law;
- (d) the Customer ceases or intends to cease to carry on business;
- (e) the Customer, being a company, experiences a change of control, which in Riedel's reasonable opinion (i) could lead to the Customer being unable to fulfil its obligations under this or any other contract then in force with Riedel or (ii) causes detriment to Riedel;
- (f) the Customer pledges or in any way charges by way of security any of the Goods, which remain the property of Riedel in accordance with the terms of the Contract Documents or purports or attempts so to do; or
- (g) Riedel believes that any of the above is likely to occur.
- 5.2. Riedel shall be entitled to exercise its rights of termination or suspension under Condition 5.1. at any time during which the event giving rise to such rights is continuing and has not been remedied and, in the event of a suspension, Riedel shall be entitled, as a condition of resuming delivery under any contract between it and the Customer, to require prepayment of, or such security as it may require for the payment of, the price of any further goods.
- 5.3. No waiver by Riedel of any breach of the Contract Documents by the Customer will be considered as a waiver of any subsequent breach of the same or any other provision.
6. Price.
- 6.1. The Contract Price shall be the total amount set out in the Order Confirmation, or, if no price is quoted, the price set out in Riedel's published price book in force at the date of delivery.
- 6.2. Riedel shall be entitled, upon giving written notice to the Customer, at any time before delivery of the Goods, to adjust the Contract Price to reflect any increase in the cost of supply of the Goods is due to any event of Force Majeure, any request by the Customer to change the delivery date(s), quantities or types of Goods ordered, or the specification, or any delay caused by any instructions of the Customer or failure of the Customer to give Riedel adequate and timely instructions or information.
- 6.3. Riedel will issue all invoices in the currency specified in the Order Confirmation.
7. Terms of Payment.
- 7.1. Payment for the Goods shall be made only by electronic bank transfer to the bank account specified by Riedel from time to time and as otherwise specified in the Contract Documents.
- 7.2. The Customer will pay Riedel the Contract Price in full and clear funds without deduction within 30 (thirty) days of the date of the invoice notwithstanding that delivery of the Goods may not have taken place and/ or that the title to the Goods has not passed to the Customer. In the case of Special Orders, a deposit of not less than 50% of the Contract Price will become due for payment on Riedel's receipt of the relevant Order, with the remaining balance due within 30 (thirty) days of such date. Payment will be deemed to have been made when cleared funds for the Goods are received in full in Riedel's bank account. The time for payment of the Contract Price shall be of the essence.
- 7.3. In the event that payment is made by the Customer in any currency other than the currency specified in the Order Confirmation, the Customer shall bear the exchange rate risk and shall not obtain title to the Goods until funds in the currency specified in the Order Confirmation are received in Riedel's bank account in respect of the total of all amounts outstanding from the Customer.
- 7.4. In the event of default or late payment by the Customer, Riedel shall be entitled, without prejudice to any other right or remedy, to charge the Customer interest on the amount unpaid at the rate of 4% above the Bank of England base rate, which shall accrue on a daily basis from the date due until payment in full is made.
- 7.5. The Customer shall pay all amounts due under the Contract in full without any set-off, counterclaim, deduction or withholding (except for any deduction or withholding required by law). Riedel may at any time, without limiting any other rights or remedies it may have, set off any amount owing to it by the Customer against any amount payable by Riedel to the Customer.
8. Notice of Defects, Warranties and Limitations.
- 8.1. Subject to the provisions of these Conditions, Goods supplied by Riedel will, at the date of delivery, conform in all material respects with any specification and standard specified in the Contract Documents. Any defects or non-conformance must be notified to Riedel in Writing in accordance with Condition 9.1. within 14 (fourteen) days of delivery of the Goods in accordance with Condition 3. and in any event prior to their use or re-sale, including a detailed description and photos of the defects or the non-conformance; otherwise, the Goods will be deemed to have been accepted.
- If the Goods are not materially in conformance with the Contract Documents and the Customer has given notice of defect or non-conformance pursuant to this Condition 8.1. (to the exclusion of any other remedy that the Customer may have in respect of the Goods):
- (a) if Riedel and the Customer agree, the Customer shall accept the Goods at an agreed discounted value or the Goods shall be made good at Riedel's expense; or
- (b) if, within 21 (twenty-one) days of the Customer giving notice to Riedel under Condition 8.1., Riedel and the Customer do not so agree, the Customer may return the Goods at Customer's cost and risk to Riedel whereupon Riedel shall, at Riedel's option, either:
- (i) if any payment has been made, refund the Customer or, if Riedel so decides, give the Customer credit for the invoice price of the defective or the non-conforming Goods (including the original, but not the return, cost of delivery).
- (ii) replace the Goods by delivering replacement Goods to the original place of delivery as soon as may be reasonably practicable.
- 8.2. Riedel shall not be liable for the Goods' failure to comply with the warranty set out in Condition 8.1. in any of the following events:
- (a) the defect arises or damage is caused as a result of Force Majeure;
- (b) the Customer makes any further use of such Goods after giving notice in accordance of any defect or non-conformance;
- (c) the defect arises because the Customer failed to follow Riedel's oral or written instructions as to the storage and use of the Goods or (if there are none) good trade practice regarding the same;
- (d) the defect arises as a result of Riedel following any drawing, design or specification supplied by the Customer;
- (e) the Customer alters or repairs such Goods without the written consent of Riedel;
- (f) the defect arises as a result of fair wear and tear, wilful damage, negligence, or abnormal storage or working conditions; or
- (g) the Goods differ from the specification as a result of changes made to ensure they comply with applicable statutory or regulatory requirements.
- 8.3. Except as provided in this Condition 8., Riedel shall have no liability to the Customer in respect of the Goods' failure to comply with the warranty set out in Condition 8.1.

8.4. Without prejudice to the provisions of Condition 8.1. and the commitments regarding compliance of the Goods to the relevant specification, any condition, warranty, statement or undertaking as to the quality of the Goods or their fitness or suitability for any purpose however or whenever expressed or which may be implied by statute (including the terms implied by Sections 13 to 15 of the Sale of Goods Act 1979 and Sections 3, 4 and 5 of the Supply of Goods and Services Act 1982), custom of the trade or otherwise is hereby excluded, except to the extent that such exclusion is prevented by law.

8.5. Subject to Conditions 8.1. and 8.6.:

(a) Under no circumstances shall Riedel be liable to the Customer for any loss, damage or expense incurred or suffered (including, but without limitation, loss of profit, revenue or goodwill or any indirect or consequential loss) howsoever arising out of or in connection with the Contract, whether in contract, tort (including negligence) or breach of statutory duty other than as set out in Condition 8.1.; and

(b) Riedel's total liability to the Customer in respect of all other losses arising under or in connection with the Contract, whether in contract, tort (including negligence), breach of statutory duty or otherwise shall be limited to the price of the Goods and shall in no event include any incidental or consequential damages of any kind.

Nothing in this Condition 8.5. affects the provisions of Condition 8.6.

8.6. Riedel shall only be liable for damage to the extent that the damage was caused by Riedel by gross negligence or wilful intent. Liability for slight negligence is excluded.

Nothing in the preceding sentence or otherwise in the Contract Documents shall limit or exclude Riedel's liability for:

(a) death or personal injury caused by its negligence;

(b) fraud or fraudulent misrepresentation;

(c) breach of the terms implied by Section 12 of the Sale of Goods Act 1979 or Section 2 of the Supply of Goods and Services Act 1982; or

(d) defective products under the Consumer Protection Act 1987; or

(e) any matter in respect of which it would be unlawful for Riedel to exclude or restrict its liability.

8.7. Decorations of any and all kind, that have not been made or commissioned by Riedel, such as engravings, silk-screenings etc., are at the sole responsibility and risk of the Customer. Riedel and its affiliated companies will not be responsible and shall be excluded from any warranty whatsoever, especially but not limited to that heavy metals or other dangerous materials are applied, or if the material used is not water-resistant or dishwasher-proof. Customer shall indemnify and hold Riedel and its affiliated companies harmless from any and all claims, suits, losses, damages, demands, injuries and expenses (including reasonable attorney's fees) arising out of or related to any claims made against Riedel based on any decorations (such as engraving, silk-screening, etc.) made to the Goods by or on behalf of the Customer.

8.8. In the event that any Goods are made or supplied to the Customer's own specification or where standard Goods of Riedel are altered in accordance with the Customer's instructions:

8.8.1. the Customer warrants and undertakes full responsibility, not only for the suitability and fitness of the specification, but that such specification does not infringe any proprietary right of any third party, and the Customer shall indemnify Riedel and its affiliated companies in full against any loss, damage or expense whatsoever (including costs), which Riedel or its affiliated companies may incur arising from the performance of the Contract by reason of any infringement of any such proprietary rights;

8.8.2. Riedel reserves the right without any liability to change the Customer's specification as required to ensure that the Goods comply with any health, safety or other statutory requirement or provision.

8.9. Conditions 8.4., 8.5., 8.7., 9.1. and 19.1. to 19.4. (inclusive), and such other provisions that by their nature are intended to survive termination, shall survive the termination of the Contract for whatever cause.

8.10. "Riedel", "Spiegelau" and "Nachtmann" branded glasses sold by Riedel are dishwasher-proof in accordance with their respective specifications. In case of eventual glass clouding, if any, notwithstanding Condition 8.1., Riedel grants a limited warranty for 2 (two) years as of the date of production of the respective Goods (bottom stamp). Mechanical damages of any kind to the surface shall be excluded from such warranty. Riedel shall, at its option, repair or replace such defective Goods or refund the price of the defective Goods if:

(a) the Customer notifies Riedel in Writing during the warranty period within a reasonable time of discovery that some or all of the branded Goods do not comply with the warranty set out in this Condition 8.10.; and

(b) Riedel is given a reasonable opportunity to examine the branded Goods; and

(c) the Customer (if required by Riedel) returns such Goods to Riedel's place of business at the Customer's cost and risk.

Riedel shall not be liable for the branded Goods failure to comply with the warranty in this Condition 8.10., if the events in Condition 8.2. (a) to (g) apply.

9. Acceptance of Goods and Returns.

9.1. The Customer shall be deemed to have accepted the Goods from the point of delivery or deemed delivery as provided in Condition 3. unless, in the case of a defect in the quality or state of the Goods or the Goods otherwise not conforming with the Contract Documents, which defect or non-conformance was apparent upon inspection or testing of the Goods (or would have been had a careful inspection or reasonable test been carried out), the Customer gives Riedel a notice specifying such defect or non-conformance within 14 (fourteen) days after receiving the Goods and in any event prior to their use or re-sale and, after doing so, gives Riedel a reasonable opportunity to inspect or test the Goods before they are used or resold.

9.2. The Customer acknowledges that for technical reasons and because of the materials used in the course of the production of glass products, deviations of products of the same series may occur, in particular with respect to size, weight, ovality or the vertical axle according to the respective technical drawings, which cannot be influenced by Riedel. Such deviations in Goods (particularly in comparison to earlier deliveries of the same type of Goods) will therefore not constitute any defect.

9.3. Unless the Goods are found to be defective under Condition 8.1., 8.9. or 9.1., no Goods may be returned to Riedel without its prior agreement. Special Orders or Goods that are engraved, decorated or personalized in any other way may not be returned. Riedel will not normally grant such agreement, unless special circumstances apply and only then, on the condition that the returned Goods must be part of the current collections currently offered for sale by Riedel and in mint, resalable condition, packed in the original undamaged boxes and in the original sealed master packs. Returns must be shipped within 30 (thirty) days after having received Riedel's written prior approval. Any returns not in conformity with the foregoing may be refused by Riedel. Subject thereto, if Riedel expressly agrees that the Goods may be returned and such Goods are not considered to be defective under Condition 9.1. on inspection by Riedel, the Customer will pay to Riedel an amount equal to 20% of the Contract Price to cover Riedel's costs of re-stocking.

9.4. In respect of all returns made under Condition 9.3., the Customer shall redeliver the Goods to a delivery point designated by Riedel, and shall be responsible for all freight and insurance costs and shall bear the risk in the Goods until returned to Riedel in accordance with the terms hereof.

10. Cancellation and Assignment.

10.1. The Customer shall have no right to cancel the Contract without the consent of Riedel, which, if given, may be given on any terms that Riedel thinks fit in its absolute discretion. The Customer shall indemnify Riedel against any loss, cost, expense, liability, claim or damage, which Riedel incurs or suffers arising out of or in connection with such cancellation. No such cancellation shall be effective unless agreed in Writing by an authorised representative of Riedel.

10.2. Without the prior written consent of Riedel, the Customer shall not assign the benefit of all or any part of its rights or sub-contract the performance of all or any part of its obligations under the Contract.

11. Force Majeure.

11.1. Riedel shall not be deemed to be in breach of this Contract or otherwise liable to the Customer for delay in performing or failure to perform any of its obligations under the Contract if and to the extent that such delay or failure results from an event of Force Majeure.

11.2. Following the occurrence of an event of Force Majeure, delivery times and periods shall be prolonged accordingly.

11.3. For the avoidance of doubt, the provisions of this Condition 11. also apply where the event of Force Majeure affects any of Riedel's suppliers.

11.4. Nothing in this Condition 11. affects the agreed payment terms.

11.5. If any Force Majeure event persists for a continuous period in excess of 3 (three) months Riedel shall be entitled to terminate the Contract by giving at least 30 (thirty) days' written notice to the Customer.

12. Severability.

In the event that, for any reason, any provision or part-provision in any of the Contract Documents is held to be or becomes void, unenforceable or otherwise invalid or illegal, any Contract, which incorporates any such Contract Document shall otherwise continue to be fully binding and all the other provisions of the Contract Document, and the remainder of any provision where the effect of some part of it is held to be void, unenforceable or otherwise invalid or illegal, shall remain fully effective.

13. Intellectual Property.

13.1. Riedel or Riedel's licensors hold any and all rights, titles, good-will, and interest of any nature whatsoever, including but not limited to any and all intellectual property rights, in particular copyrights, trademarks, trade secrets, patent rights and/ or design rights, relating to the Goods, the Goods designs, the glassware samples and the glassware sample designs, including, but not limited to, the respective drawings, tools, shapes and moulds.

13.2. Any tools, moulds, drawings and plans provided to a Customer are the sole property of Riedel and its licensors, including but not limited to any and all intellectual property, even if Customer bears the costs of their acquisition in part or in full, and will not be handed back at the end of any kind of communication or cooperation and Riedel and its licensors retain the right to use such tools, moulds, drawings and plans at its sole discretion without any liability to the Customer.

13.3. The Contract Documents do not grant the Customer any proprietary right in or licence to use or exploit any Intellectual Property or any of the Trade Marks whatsoever save that the Customer may use any such Intellectual Property and Trade Marks as Riedel may determine:

(a) for the purpose only of its display and promotion of the Goods; or

(b) with Riedel's prior written consent.

13.4. The Customer acknowledges that all goodwill associated with the use of the Trade Marks by the Customer vests, and shall vest, in Riedel or its licensors, where applicable, and that if any goodwill or proprietary right in relation to any of the Trade Marks vests in the Customer, the Customer shall assign such goodwill or right to Riedel or its licensors, where

applicable.

13.5. Any use of trademarks, names, logos, photos, videos, and company symbols of Riedel or of Riedel's licensors or the Trade Marks in publications, electronic (online) advertising, social media pages, or printed matter is only permitted with Riedel's prior written consent. In addition, Customer undertakes not to use any trademarks, names, logos, photos, videos and company symbols that are likely to be confused with those of Riedel or of Riedel's licensors, or with "Riedel", "Spiegelau" or "Nachtmann" or similar signs or to have them protected in any form whatsoever.

13.6. Any and all materials and related documentation (including any publications, brochures, catalogues, illustrations, samples and designs) Riedel provides to the Customer hereunder or through any contract together with any and all Intellectual Property rights, brand names of Riedel and its licensors as well as all goodwill and copyright, in and arising from the brand names and the Goods, vested therein or related thereto remain the sole and exclusive property of Riedel or its licensors. Documents such as catalogues, brochures, illustrations, photos, videos, and the like as well as samples and designs remain at all times the intellectual property of Riedel or of Riedel's licensors. The Customer undertakes not to distribute, copy, circulate or make such material and documentation available to third parties, either in whole or in part, without the prior written consent of Riedel or to use them for any purpose other than as specified in the Contract Documents or otherwise by Riedel. In the event that Riedel does grant consent to the Customer to make such material and documentation available to third parties, the Customer shall be obliged to impose all obligations arising out of these Conditions upon such third party. The Customer remains liable vis-à-vis Riedel for any acts or omissions of such third party, and the Customer shall indemnify and hold Riedel harmless from any and all claims and expenses (including reasonable legal fees) arising out of or related to any such acts or omissions.

13.7. Any use of the brand names or of any Intellectual Property or intellectual property rights of Riedel's licensors on social media platforms such as Facebook, Twitter, Instagram etc. or any setting up of a "Riedel", "Spiegelau" or "Nachtmann" account on such social media platforms shall only be permitted upon prior written consent of Riedel.

13.8. The Customer undertakes not to commit or omit any act which may damage the goodwill or reputation attaching to the Intellectual Property or any of the Trade Marks or which may be detrimental to or damage the good name, reputation or image of Riedel or the Goods.

13.9. The Customer shall not adopt or use any mark, name, logo, design or symbol, which incorporates or is confusingly similar to any of the Trade Marks. The Customer shall not at any time apply anywhere in the world to register any mark, name, domain, logo, design or symbol, which incorporates or is confusingly similar to any of the Trade Marks.

13.10. If no Order is placed by the Customer, all materials and documentation provided to the Customer must be returned to Riedel at the Customer's cost. Riedel may at any time require that all materials, documentation and copies made thereof are returned to it by the Customer immediately at the Customer's cost.

14. Reselling Restrictions.

14.1. The Customer undertakes:

(a) not to resell the Goods to any person, corporation, partnership, sole trader, company or other entity, who intends to resell the Goods for any business or trade purpose after purchase from the Customer; and

(b) to only sell the Goods to end user customers.

14.2. Any preferential conditions on which Customers may purchase packs containing free products (Value Packs) must to the extent legally permissible be passed on to the end-consumer in at least the same amount. The Customer undertakes not to unpack Value Packs and not to sell individually any merchandise included in Value Packs.

14.3. On-premise glass collections are strictly for use in the hospitality industry, and are not intended for resale, the retail trade and/or end-consumers.

14.4. The Customer acknowledges that the packaging and labelling of the Goods as designed and implemented by Riedel or Riedel's suppliers is critical to maintain the brand recognition and image of the respective brand names. Without the prior written consent of Riedel, the Customer shall not modify or remove any packaging, labelling, markings or other items, such as promotional materials or instructions, affixed to the Goods themselves or their packaging or accompanying the Goods as shipped to the Customer. The Goods shall not be unpacked from their original packaging as shipped to the Customer or be repacked by the Customer.

14.5. The Customer acknowledges its obligation to maintain the extremely high standard of the Goods sold by Riedel as some of the world's finest glassware and the goodwill symbolized by the Trade Marks and the Goods and to refrain from any conduct that could be viewed as having a negative impact on the image of Riedel and its affiliates companies or the respective Goods as determined in Riedel's sole discretion.

14.6. The Customer will conduct its activities strictly in accordance with these Conditions and all applicable laws and regulations.

14.7. If the Customer knowingly contravenes any of Conditions 14.1. to 14.6. (inclusive), Riedel may immediately terminate all contracts then in place with the Customer and/or, without prejudice to any other right or remedy, receive from the Customer damages equal to the amount received by the Customer from the relevant sale.

15. Third Parties.

The Customer and Riedel agree that no term of the Contract shall be enforceable, by virtue of the Contracts (Rights and Third Parties) Act 1999, by any person, who is not a party to the Contract Documents.

16. Data Protection.

16.1. Riedel shall have the right to hold information supplied by the Customer and to use it to process the Order and to inform the Customer of new ranges, products and prices.

16.2. Riedel shall have the right to conduct credit and other checks and use credit scoring techniques and to pass the Customer's details to credit reference agencies (who shall have the right to retain their own record).

16.3. Riedel shall have the right to share information about the Customer with its group companies and they shall have the right to send the Customer information about their other goods or services, which they believe may be of interest.

16.4. Unless the Customer requests otherwise, Riedel shall also have the right to pass details about the Customer and its account(s) to other carefully selected reputable companies, who may wish to offer the Customer other goods or services, which Riedel believes may be of interest.

16.5. Offerings of further goods or services by Riedel and other members of the Riedel group, or other carefully selected reputable companies, may be made to the Customer by any means (including by telephone).

16.6. The Customer is entitled to a copy of the information Riedel holds concerning it by Writing to Riedel and requesting it. A reasonable fee may be payable for this service.

16.7. The Customer shall not, without the prior written consent of Riedel, submit to Riedel any personal data.

16.8. If the Customer submits personal data to Riedel in breach of Condition 16.7., the Customer warrants and represents that it has all necessary and appropriate consents and notices in place to enable lawful transfer of personal data to Riedel for the duration and purposes of the Contract.

16.9. The Customer shall indemnify Riedel in respect of all loss, and damage, cost, expense (including legal fees), administrative sanction, fine, penalty, action or other liability that Riedel incurs as a result of any breach of this Condition 16. and/or any data protection legislation and in particular, without limiting the foregoing, the Customer shall indemnify Riedel in respect of all any loss and, damage, cost, expense (including legal fees), administrative sanction, fine, penalty, action or other liability incurred as a result of enquiry or complaint by a data subject or enquiry or investigation by the Information Commissioners Office or such other organisation carrying out the same or similar functions as in place at the relevant time.

17. Notices.

17.1. Any notice or other communication required or permitted to be given or made under the Contract Documents shall be in Writing and shall be deemed to have been duly given or made if delivered:

(a) in the case of Riedel, at Lakeside House, 3 Trentham Office Village, Bellringer Road, Trentham Lakes South, Stoke on Trent, ST4 8GH, UK and

(b) in the case of the Customer, at the address given to Riedel by the Customer.

17.2. Any such notice or communication shall be delivered by hand or by post and if delivered by hand shall be deemed to have been given upon delivery at the address of the relevant party, if sent by facsimile upon receipt thereof in legible form by the recipient and if sent by first class post upon delivery.

17.3. Either party may change its notice details on giving notice to the other party of the change in accordance with this Condition 17. That notice shall only be effective on the 5. (fifth) day after the notification has been received or such later date as may be specified in the notice.

17.4. A notice given under these Conditions is not valid if sent by email.

18. Anti-Bribery.

The Customer shall comply with all applicable laws, statutes, regulations and codes relating to anti-bribery and anti-corruption including, but not limited to, The Bribery Act 2010.

19. Entire Agreement.

19.1. The Contract Documents constitute the entire agreement between the parties and supersede and extinguish all previous agreements, promises, assurances, warranties, representations and understandings between them, whether written or oral, relating to its subject matter.

19.2. Any conflict or inconsistency in the terms of the Contract Documents shall be resolved by giving precedence in the following order: (1) the Order Confirmation; (2) these Conditions; (3) the Delivery Note; and (4) any other document referred to at (d) in the definition of "Contract Documents".

19.3. The Customer acknowledges that in entering into the Contract it is not relying upon any pre-contractual statement, which is not set out in the Contract Documents.

19.4. Except in the case of fraud, neither party shall have any right of action against the other party to this Contract arising out of or in connection with any pre-contractual statement except to the extent that it is repeated in the Contract Documents.

19.5. For the purposes of this condition, 'pre-contractual statement' means any samples, drawings, descriptive matter or advertising produced by Riedel or any draft, agreement, undertaking, representation, warranty, promise, assurance or arrangement of any nature whatsoever, whether or not in Writing, relating to the subject matter of the Contract made or given by either party to the other at any time prior to the date of this Contract.

20. Governing Law and Jurisdiction.

The Contract, and any dispute or claim (including non-contractual disputes or claims) arising out of or in connection with it shall be governed by and construed in accordance with the law of England and Wales. Each party irrevocably agrees that the courts of England and Wales shall have exclusive jurisdiction to settle any dispute or claim (including non-contractual disputes or claims) arising out of or in connection with the Contract or its subject matter or formation.

**AUSTRIA****Tiroler Glashütte GmbH**

Weissachstraße 28-34
6330 Kufstein, Austria
Phone: +43 (0) 5372 64896
Fax: +43 (0) 5372 63225
Email: info@riedel.com

**JAPAN****RSN Japan Co. Ltd**

Aoyama Twin Tower (West) 2 F
1-1-1 Minami-Aoyama
Minato-Ku, Tokyo 107-0062, Japan
Phone: +81 3 4530 6900
Fax: +81 3 5775 5889
Email: info@riedel.co.jp
www.riedel.co.jp

**AUSTRALIA****RSN Australia Pty Ltd**

201/32 Walker Street
North Sydney NSW 2060, Australia
Phone: +61 2 9966 0033
Fax: +61 2 9906 7802
Email: info@rsnaustralia.com.au

**NEW ZEALAND****RSN New Zealand Pty Limited**

PO Box 99841
Newmarket 1149 Auckland, NZ
Phone: +612 99 66 00 33
Email: info@rsn.co.nz

**CANADA****Crystal of Canada, Inc.**

110 Fieldcrest Avenue
Raritan Plaza 1, 4th Floor
Edison, NJ 08837, USA
Phone: +1 888 4-RIEDEL
Fax: +1 732 346 8977
Email: info@riedelcanada.com

**SWITZERLAND****RSN-Schweiz GmbH**

c/o KD Zug Fiduciary Ltd.
Untermüli 7, Postfach 7444
6302 Zug, Switzerland
Phone: +41 41 766 26 35
Email: webshopsui@riedel.com

**CHINA****RSN Crystal Trading
(Shanghai) Ltd.**

RM2301-2302 Citic Plaza
859 Sichuan Road North
Shanghai 200085, China
Phone: +86 21 60707358
Email: info.asia@riedel.com

**UNITED KINGDOM****RSN.UK Ltd t/a Riedel**

Lakeside House
3 Trentham Office Village
Trentham Lakes South
Stoke on Trent, ST4 8GH
United Kingdom
Phone: +44 (0) 1782 646 105
Email: info@riedel.co.uk

**FRANCE****RSN Crystal France**

22 rue du Sentier
75002 Paris
Phone: +33 1 42 89 86 08
Email: riedelfrance@riedel.com

**USA****Crystal of America, Inc.**

110 Fieldcrest Avenue
Raritan Plaza 1, 4th Floor
Edison, NJ 08837, USA
Phone: +1 732 346 8960
Fax: +1 732 346 8977
Email: info@riedelusa.com

**GERMANY****RSN Deutschland GmbH Vertrieb**

Zacharias-Frank-Straße 7
D-92660 Neustadt a.d. Waldnaab
Phone: +49 (0) 9602 30-0
Fax: +49 (0) 9602 30-1100
Email: info@riedel.com

RIEDEL.COM